

4

3

2

1

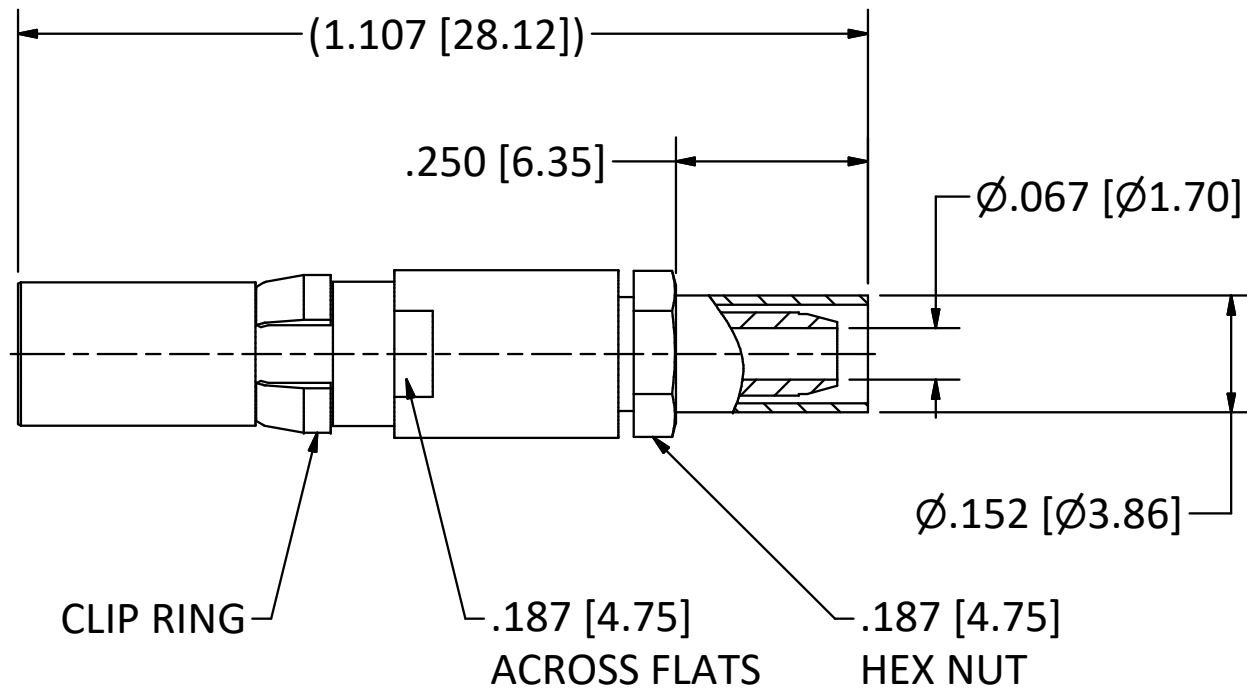
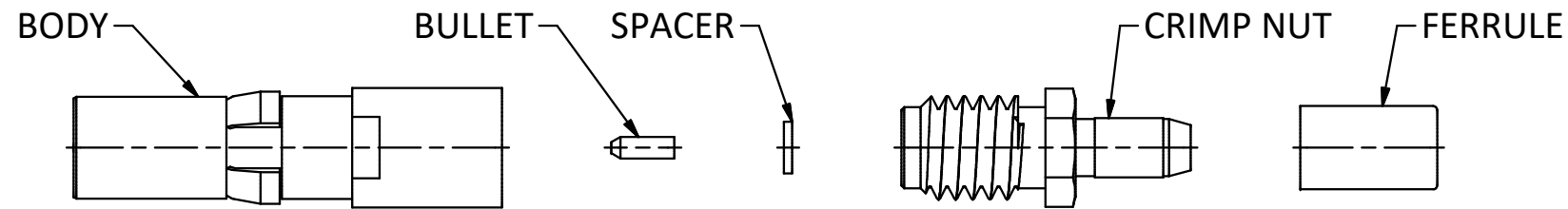

NOTES:

- 1. SPECIFICATIONS PER IDS-26.
- 2. BULLET, SPACER, CRIMP NUT, AND FERRULE SHIPPED LOOSE.
- 3. ACCOMMODATES RG-174, RG-179, RG-187, RG-188, OR RG-316 CABLE.
- 4. CRIMP USING .128 HEX DIE (M22520/5-03).

HOUSING: D-SUBMINIATURE, SIZE 8 CAVITY.

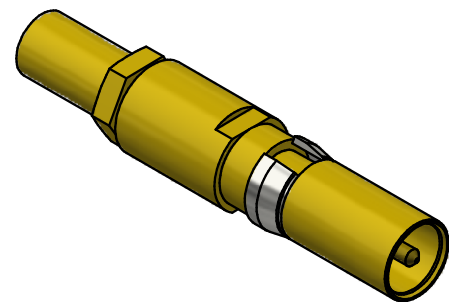

SCALE 2.5 : 1

REV.	DESCRIPTION	DATE	BY
S	ECN 10702	11/10/10	JEM
R	ECN 10294	4/20/10	JEM
Q	ECN 9706	12/10/08	JEM
P	ECN 9273	2/25/08	JEM
M	ECN 4445	3/27/98	HN

This drawing embodies a proprietary design of The Phoenix Company of Chicago, Inc., Naugatuck, CT 06770. All design, manufacturing, reproduction, use, sale, and other rights regarding the same are expressly reserved. The information in this drawing may be covered completely or in part by patents and/or patents pending.

WARNING - THIS DOCUMENT CONTAINS TECHNICAL DATA WHOSE EXPORT IS RESTRICTED BY THE ARMS EXPORT CONTROL ACT (TITLE 22, U.S.C., SEC 2751, ET. SEQ.) OR THE EXPORT ADMINISTRATION ACT OF 1979, AS AMENDED, TITLE 50, U.S.C., APP 2401 ET SEQ. VIOLATIONS OF THESE EXPORT LAWS ARE SUBJECT TO SEVERE CRIMINAL PENALTIES. DISSEMINATE IN ACCORDANCE WITH PROVISIONS OF DOD DIRECTIVE 5230.25.

Filename: ver2\Autodesk Inventor Data Base\Assemblies\26 Series\26-1080-0670-CU.idw

UNLESS OTHERWISE SPECIFIED, PHOENIX WORKMANSHIP STANDARDS APPLY DIMENSIONS IN INCHES OR (METRIC)

DO NOT SCALE PRINTS
TOLERANCES ARE:
FRACTIONS: ± 1/64
DECIMALS: .XX ± .01
.XXX ± .003
ANGLES: ± 1/2°

32√

APPROVALS	DATE
DRAWN YT	11/23/1988
CHECKED HN	11/23/1988
QA	
MFG	
ENGINEER YT	11/23/1988
APPROVED HN	11/23/1988

The PHOENIX Company of Chicago, Inc.

22 GREAT HILL RD., NAUGATUCK, CT 06770
WWW.PHOENIXOFCHICAGO.COM
PHONE: (800) 323-9562 FAX:(630) 206-1801

TITLE
**PKZ® RECEPTACLE, CRIMP/CLAMP
TERMINATION**

SIZE	FSCM	DWG NO	REV	PLATING OPT.
B	58167	26-1080-0670	S	A, B, C, D
SCALE	2.5 : 1	F.S.R. #	SHEET	1 OF 1

4

3

2

1