

4

3

2

1

B

B

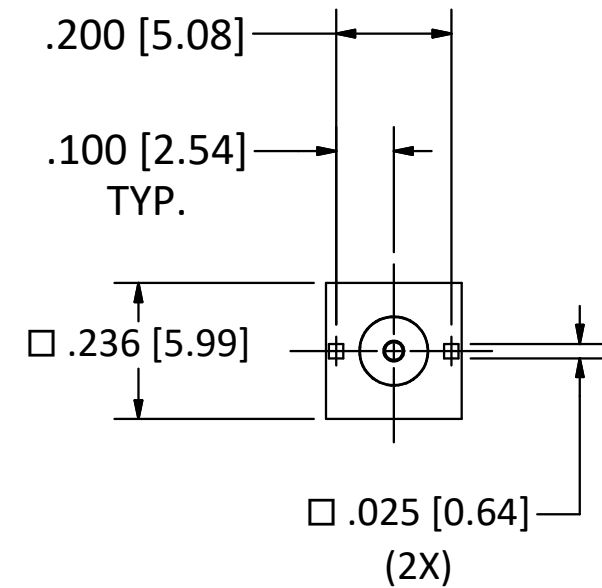
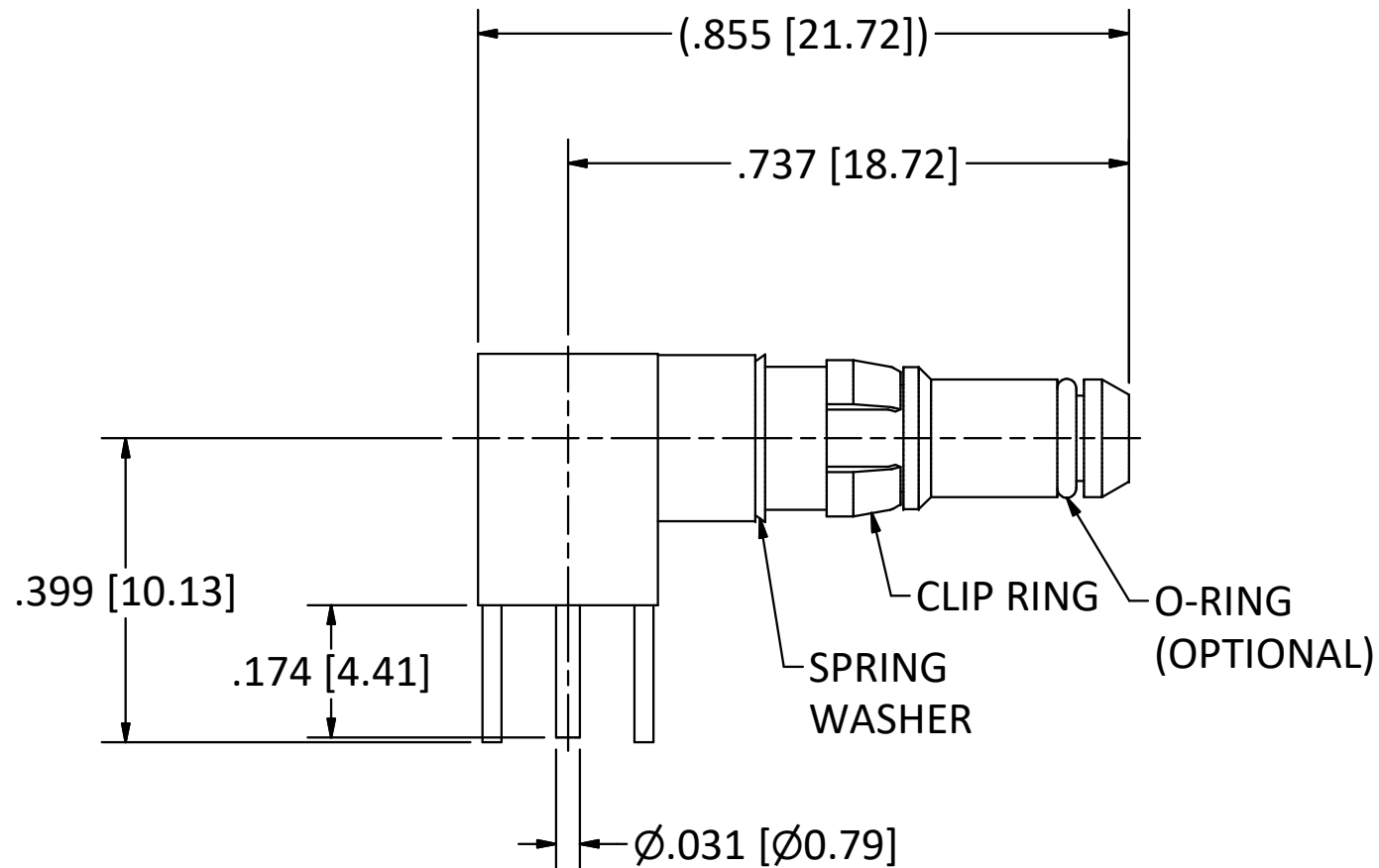
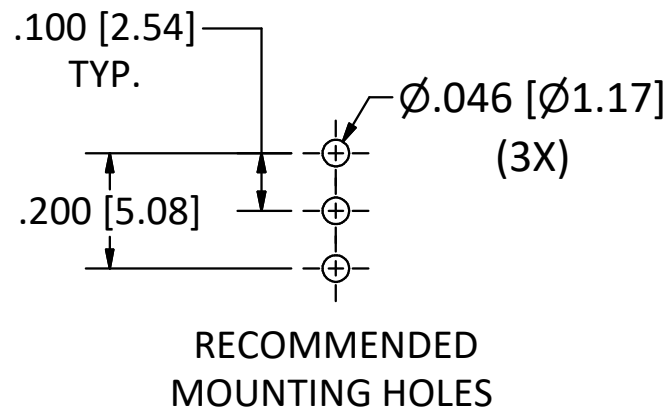

NOTES:  
 1. SPECIFICATIONS PER IDS-26.  
**HOUSING:** D-SUBMINIATURE, SIZE 8 CAVITY.

PART NUMBER	O-RING OPTIONS
26-2450-73	NONE
26-2451-73	ENVIRONMENTAL
26-2453-73	EMI SPRING
26-2455-73	GROUNDING RING

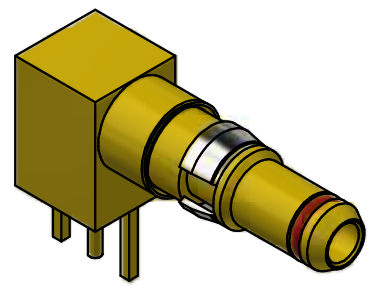

SCALE 2.5 : 1

REV	DESCRIPTION	DATE	BY
J	ECN 13678	2/10/20	JEM
I	ECN 13156	11/6/18	JEM
H	ECN 11486	10/24/12	JEM
G	ECN 10284	4/14/10	JEM
F	ECN 10079	11/4/09	JEM
E	ECN 6595	4/25/02	HN

This drawing embodies a proprietary design of The Phoenix Company of Chicago, Inc., Naugatuck, CT 06770. All design, manufacturing, reproduction, use, sale, and other rights regarding the same are expressly reserved. The information in this drawing may be covered completely or in part by patents and/or patents pending.

WARNING - THIS DOCUMENT CONTAINS TECHNICAL DATA WHOSE EXPORT IS RESTRICTED BY THE ARMS EXPORT CONTROL ACT (TITLE 22, U.S.C., SEC 2751, ET. SEQ.) OR THE EXPORT ADMINISTRATION ACT OF 1979, AS AMENDED, TITLE 50, U.S.C., APP 2401 ET SEQ. VIOLATIONS OF THESE EXPORT LAWS ARE SUBJECT TO SEVERE CRIMINAL PENALTIES. DISSEMINATE IN ACCORDANCE WITH PROVISIONS OF DOD DIRECTIVE 5230.25.

Filename: ver2\Autodesk Inventor Data Base\Assemblies\26 Series\26-245X-73-CU.idw

UNLESS OTHERWISE SPECIFIED, PHOENIX WORKMANSHIP STANDARDS APPLY DIMENSIONS IN INCHES OR (METRIC)

DO NOT SCALE PRINTS  
 TOLERANCES ARE:  
 FRACTIONS: ± 1/64  
 DECIMALS: .XX ± .01  
 .XXX ± .003  
 ANGLES: ± 1/2°



APPROVALS	DATE
DRAWN HN	4/30/1991
CHECKED JEM	4/30/1991
QA	
MFG	
ENGINEER JEM	4/30/1991
APPROVED HN	4/30/1991

**The PHOENIX Company of Chicago, Inc.**  
 22 GREAT HILL RD., NAUGATUCK, CT 06770  
 WWW.PHOENIXOFCHICAGO.COM  
 PHONE: (800) 323-9562 FAX:(630) 206-1801

TITLE <b>PkZ® RIGHT ANGLE PLUG, PRINTED CIRCUIT MOUNT</b>			
SIZE <b>B</b>	FSCM 58167	DWG NO <b>26-245X-73</b>	REV J
SCALE 2.5 : 1	F.S.R. #	SHEET 1	PLATING OPT. A, B, C, D

4

3

2

1

A

A