

4

3

2

1

B

B

(Ø.250 [Ø6.35])

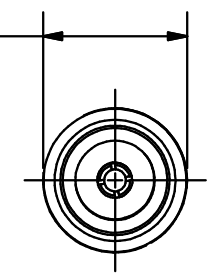

(1.265 [32.13])

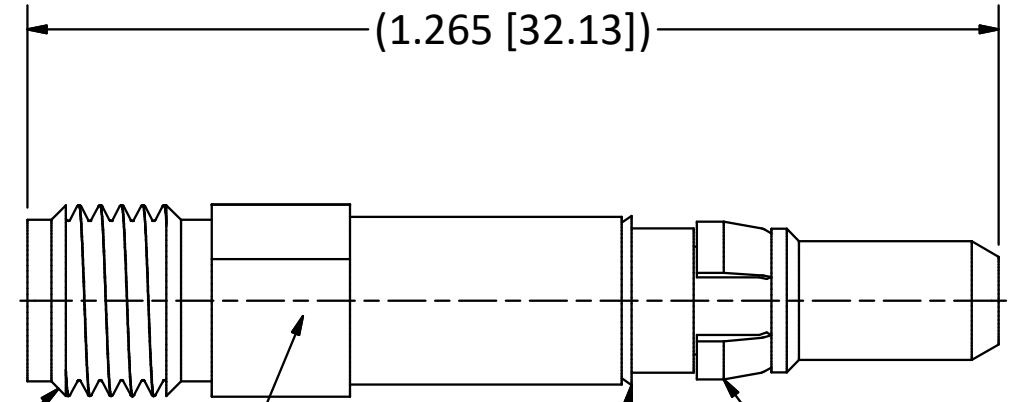

1/4-36 UNS - 2A THREADS

.218 [5.54] ACROSS FLATS

SPRING WASHER

CLIP RING

NOTES:
 1. SPECIFICATIONS PER IDS-26 AND IDS-05.
HOUSING: D-SUBMINIATURE, SIZE 8 CAVITY.

A

A

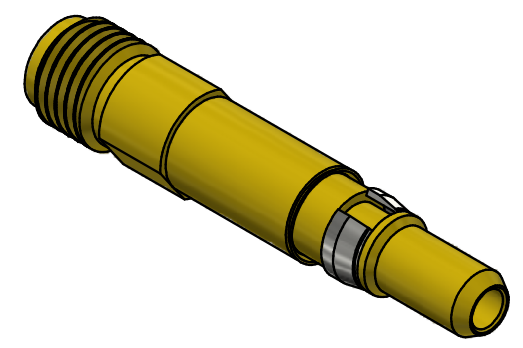

SCALE 2.5 : 1

REV.	DESCRIPTION	DATE	BY
G	PER ECN 13047	7/3/18	JEM
F	PER ECN 12550	7/5/17	RMB
E	PER ECN 12082	1/22/15	JEM
D	PER ECN 11974	9/8/14	JEM
C	PER ECN 11946	8/4/14	JEM
B	PER ECN 11850	2/4/14	JEM
A	REL. PER ECN 11835	1/14/14	JEM

This drawing embodies a proprietary design of The Phoenix Company of Chicago, Inc., Naugatuck, CT 06770. All design, manufacturing, reproduction, use, sale, and other rights regarding the same are expressly reserved. The information in this drawing may be covered completely or in part by patents and/or patents pending.

WARNING - THIS DOCUMENT CONTAINS TECHNICAL DATA WHOSE EXPORT IS RESTRICTED BY THE ARMS EXPORT CONTROL ACT (TITLE 22, U.S.C., SEC 2751, ET. SEQ.) OR THE EXPORT ADMINISTRATION ACT OF 1979, AS AMENDED, TITLE 50, U.S.C., APP 2401 ET SEQ. VIOLATIONS OF THESE EXPORT LAWS ARE SUBJECT TO SEVERE CRIMINAL PENALTIES. DISSEMINATE IN ACCORDANCE WITH PROVISIONS OF DOD DIRECTIVE 5230.25.

Filename: ver2\Autodesk Inventor Data Base\Adaptors\2605\2605-0100-00-CU.idw

UNLESS OTHERWISE SPECIFIED, PHOENIX WORKMANSHIP STANDARDS APPLY DIMENSIONS IN INCHES OR (METRIC)

DO NOT SCALE PRINTS
 TOLERANCES ARE:
 FRACTIONS: ± 1/64
 DECIMALS: .XX ± .01
 .XXX ± .003
 ANGLES: ± 1/2°

32√

APPROVALS	DATE
DRAWN JEM	1/14/2014
CHECKED	
QA	
MFG	
ENGINEER LRG	1/4/2014
APPROVED	

The PHOENIX Company of Chicago, Inc.
 22 GREAT HILL RD., NAUGATUCK, CT 06770
 WWW.PHOENIXOFCHICAGO.COM
 PHONE: (800) 323-9562 FAX:(630) 206-1801

TITLE
ADAPTER, PkZ® PLUG TO 3.5mm RECEPTACLE

SIZE B	FSCM 58167	DWG NO 2605-0100-00	REV G	PLATING OPT. G
SCALE 4: 1	F.S.R. #	SHEET 1	OF 1	

4

3

2

1