

4

3

2

1

B

B

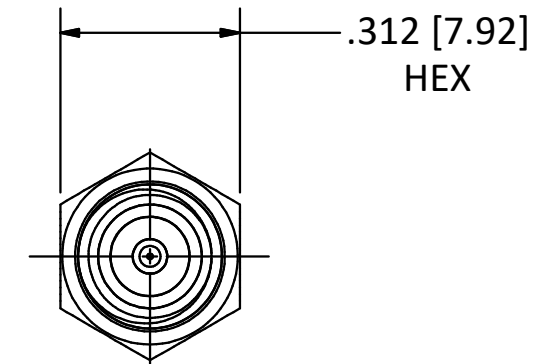
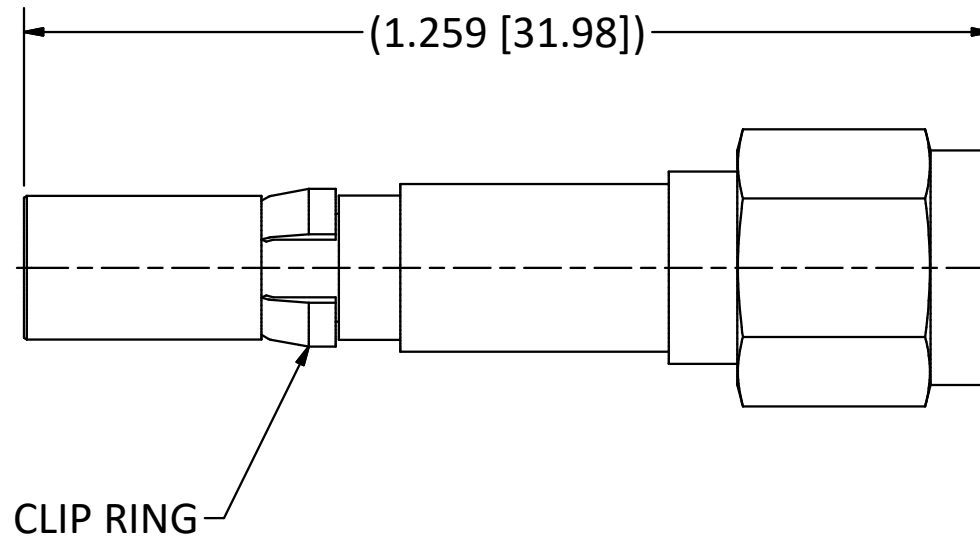

NOTES:  
 1. SPECIFICATIONS PER IDS-26 AND IDS-05.  
**HOUSING:** D-SUBMINIATURE, SIZE 8 CAVITY.

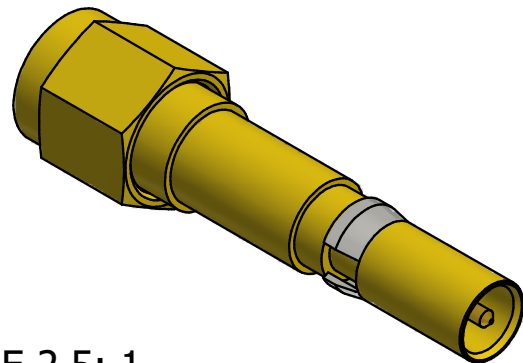

SCALE 2.5: 1

4

3

2

1

A

A

<table border="1"> <tr><td>C</td><td>PER ECN 13083</td><td>9/7/18</td><td>JEM</td></tr> <tr><td>B</td><td>PER ECN 12551</td><td>7/5/17</td><td>RMB</td></tr> <tr><td>A</td><td>REL. PER ECN 12193</td><td>8/4/15</td><td>RMB</td></tr> <tr><td>REV.</td><td>DESCRIPTION</td><td>DATE</td><td>BY</td></tr> </table>				C	PER ECN 13083	9/7/18	JEM	B	PER ECN 12551	7/5/17	RMB	A	REL. PER ECN 12193	8/4/15	RMB	REV.	DESCRIPTION	DATE	BY	<p>This drawing embodies a proprietary design of The Phoenix Company of Chicago, Inc., Naugatuck, CT 06770. All design, manufacturing, reproduction, use, sale, and other rights regarding the same are expressly reserved. The information in this drawing may be covered completely or in part by patents and/or patents pending.</p>		<p>WARNING - THIS DOCUMENT CONTAINS TECHNICAL DATA WHOSE EXPORT IS RESTRICTED BY THE ARMS EXPORT CONTROL ACT (TITLE 22, U.S.C., SEC 2751, ET. SEQ.) OR THE EXPORT ADMINISTRATION ACT OF 1979, AS AMENDED, TITLE 50, U.S.C., APP 2401 ET SEQ. VIOLATIONS OF THESE EXPORT LAWS ARE SUBJECT TO SEVERE CRIMINAL PENALTIES. DISSEMINATE IN ACCORDANCE WITH PROVISIONS OF DOD DIRECTIVE 5230.25.</p>		<p>Filename: ver2\Autodesk Inventor Data Base\Adaptors\2605\2605-1000-00-CU.idw</p> <table border="1"> <tr><th>UNLESS OTHERWISE SPECIFIED, PHOENIX WORKMANSHIP STANDARDS APPLY DIMENSIONS IN INCHES OR (METRIC)</th><th>APPROVALS</th><th>DATE</th></tr> <tr><td rowspan="5">DO NOT SCALE PRINTS  TOLERANCES ARE: FRACTIONS: ± 1/64 DECIMALS: .XX ± .01 .XXX ± .003 ANGLES: ± 1/2'</td><td>DRAWN</td><td></td></tr> <tr><td>CHECKED</td><td></td></tr> <tr><td>QA</td><td></td></tr> <tr><td>MFG</td><td></td></tr> <tr><td>ENGINEER</td><td></td></tr> <tr><td>APPROVED</td><td></td></tr> </table>		UNLESS OTHERWISE SPECIFIED, PHOENIX WORKMANSHIP STANDARDS APPLY DIMENSIONS IN INCHES OR (METRIC)	APPROVALS	DATE	DO NOT SCALE PRINTS  TOLERANCES ARE: FRACTIONS: ± 1/64 DECIMALS: .XX ± .01 .XXX ± .003 ANGLES: ± 1/2'	DRAWN		CHECKED		QA		MFG		ENGINEER		APPROVED		<p><b>The PHOENIX Company of Chicago, Inc.</b>        22 GREAT HILL RD., NAUGATUCK, CT 06770        WWW.PHOENIXOFCHICAGO.COM        PHONE: (800) 323-9562 FAX:(630) 206-1801</p>	
C	PER ECN 13083	9/7/18	JEM																																								
B	PER ECN 12551	7/5/17	RMB																																								
A	REL. PER ECN 12193	8/4/15	RMB																																								
REV.	DESCRIPTION	DATE	BY																																								
UNLESS OTHERWISE SPECIFIED, PHOENIX WORKMANSHIP STANDARDS APPLY DIMENSIONS IN INCHES OR (METRIC)	APPROVALS	DATE																																									
DO NOT SCALE PRINTS  TOLERANCES ARE: FRACTIONS: ± 1/64 DECIMALS: .XX ± .01 .XXX ± .003 ANGLES: ± 1/2'	DRAWN																																										
	CHECKED																																										
	QA																																										
	MFG																																										
	ENGINEER																																										
APPROVED																																											
				<p>TITLE  <b>ADAPTER, PkZ® RECEPTACLE TO 3.5mm PLUG</b></p>		SIZE <b>B</b>	FSCM 58167	DWG NO <b>2605-1000-00</b>	REV C	PLATING OPT. G																																	
				<p>SCALE 4 : 1</p>		F.S.R. #		SHEET 1 OF 1																																			