

4

3

2

1

B

B

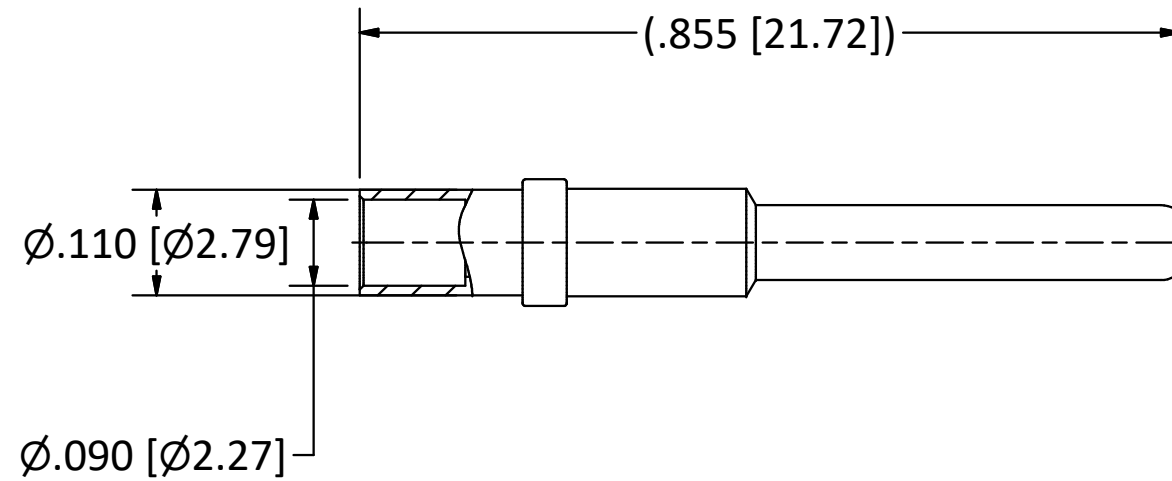

NOTES:

- 1. SPECIFICATIONS PER IDS-268.
 - 2. ACCOMMODATES RG-405 (.086 SEMI-RIGID) OR EQUIVALENT FLEXIBLE CABLE.
- HOUSING:** ARINC 600 CONNECTOR PER MIL-C-83527/3, SIZE 16 CAVITY.

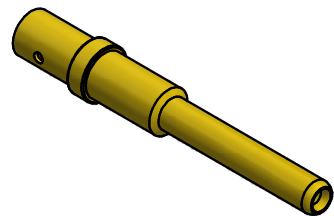

SCALE 2.5 : 1

D	PER ECN 13692	2/13/2020	JEM
C	PER ECN 13148	10/12/2018	JEM
B	PER ECN 13023	6/29/2018	JEM
A	PER ECN 12941	5/18/18	BH
REV	DESCRIPTION	DATE	BY

This drawing embodies a proprietary design of The Phoenix Company of Chicago, Inc., Naugatuck, CT 06770. All design, manufacturing, reproduction, use, sale, and other rights regarding the same are expressly reserved. The information in this drawing may be covered completely or in part by patents and/or patents pending.

WARNING - THIS DOCUMENT CONTAINS TECHNICAL DATA WHOSE EXPORT IS RESTRICTED BY THE ARMS EXPORT CONTROL ACT (TITLE 22, U.S.C., SEC 2751, ET. SEQ.) OR THE EXPORT ADMINISTRATION ACT OF 1979, AS AMENDED, TITLE 50, U.S.C., APP 2401 ET SEQ. VIOLATIONS OF THESE EXPORT LAWS ARE SUBJECT TO SEVERE CRIMINAL PENALTIES. DISSEMINATE IN ACCORDANCE WITH PROVISIONS OF DOD DIRECTIVE 5230.25.

Filename: ver2\Autodesk Inventor Data Base\Assemblies\268 Series\268-0021-0860-CU.idw

UNLESS OTHERWISE SPECIFIED, PHOENIX WORKMANSHIP STANDARDS APPLY DIMENSIONS IN INCHES OR (METRIC)

DO NOT SCALE PRINTS
TOLERANCES ARE:
FRACTIONS: ± 1/64
DECIMALS: .XX ± .01
.XXX ± .003
ANGLES: ± 1/2°



APPROVALS	DATE
DRAWN BH	5/18/2018
CHECKED JEM	5/18/2018
QA	
MFG	
ENGINEER BH	5/18/2018
APPROVED JEM	5/18/2018

The **PHOENIX** Company of Chicago, Inc.

22 GREAT HILL RD., NAUGATUCK, CT 06770
WWW.PHOENIXOFCHICAGO.COM
PHONE: (800) 323-9562 FAX:(630) 206-1801

TITLE
PKZ® PLUG, DIRECT SOLDER TERMINATION

SIZE B	FSCM 58167	DWG NO 268-0021-0860	REV D	PLATING OPT. A, C
SCALE 5 : 1	F.S.R. #	SHEET 1	OF 1	

4

3

2

1

A

A