

4

3

2

1

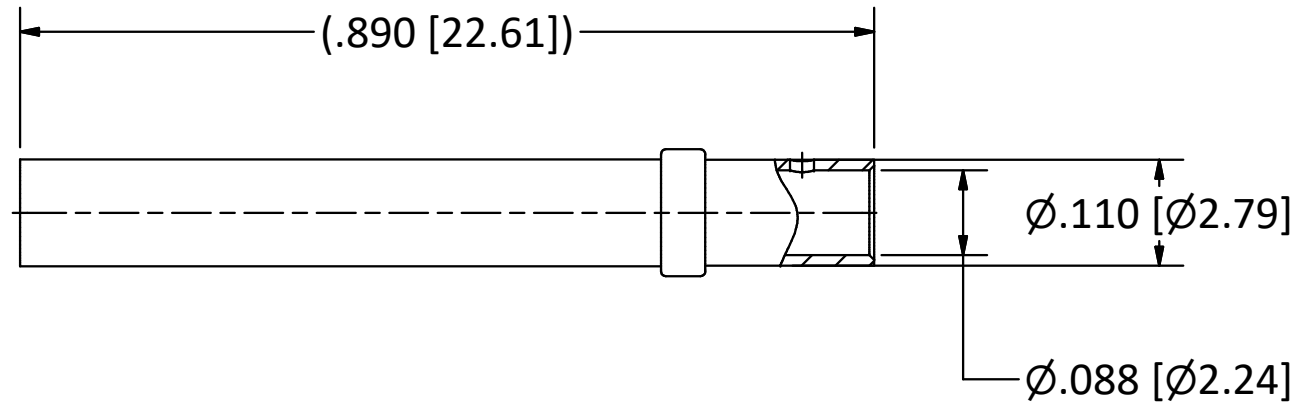
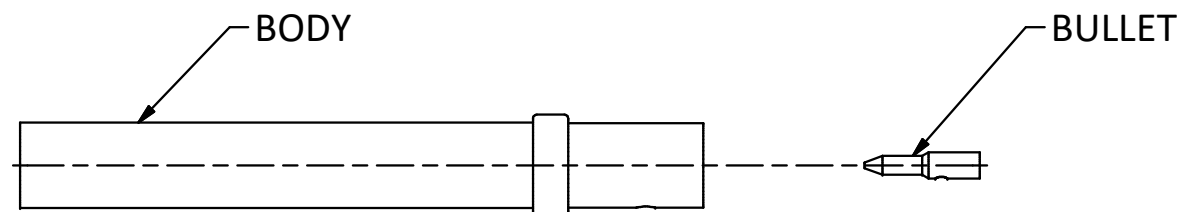

- NOTES:
1. SPECIFICATIONS PER IDS-268.
 2. BULLET SHIPPED LOOSE.
 3. ACCOMMODATES RG-174, RG-179, RG-187, RG-188, OR RG-316 CABLE.
 4. FREQUENCY: DC TO 3 GHz.
- HOUSING:** ARINC 600 CONNECTOR PER MIL-C-83527/3, SIZE 16 CAVITY.

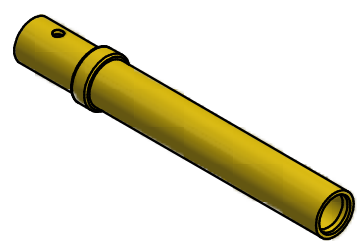

SCALE 2.5 : 1

E	PER ECN 13319	8/15/2019	RMB
D	PER ECN 13077	8/28/2018	BH
C	PER ECN 12981	6/7/2018	JEM
B	PER ECN 12952	5/22/2018	BH
A	PER ECN 12524	6/1/2017	RMB
REV	DESCRIPTION	DATE	BY

This drawing embodies a proprietary design of The Phoenix Company of Chicago, Inc., Naugatuck, CT 06770. All design, manufacturing, reproduction, use, sale, and other rights regarding the same are expressly reserved. The information in this drawing may be covered completely or in part by patents and/or patents pending.

WARNING - THIS DOCUMENT CONTAINS TECHNICAL DATA WHOSE EXPORT IS RESTRICTED BY THE ARMS EXPORT CONTROL ACT (TITLE 22, U.S.C., SEC 2751, ET. SEQ.) OR THE EXPORT ADMINISTRATION ACT OF 1979, AS AMENDED, TITLE 50, U.S.C., APP 2401 ET SEQ. VIOLATIONS OF THESE EXPORT LAWS ARE SUBJECT TO SEVERE CRIMINAL PENALTIES. DISSEMINATE IN ACCORDANCE WITH PROVISIONS OF DOD DIRECTIVE 5230.25.

Filename: ver2\Autodesk Inventor Data Base\Assemblies\268 Series\268-1021-0670-CU.idw		
UNLESS OTHERWISE SPECIFIED, PHOENIX WORKMANSHIP STANDARDS APPLY DIMENSIONS IN INCHES OR (METRIC)	APPROVALS	DATE
	DRAWN JEM	6/1/2017
DO NOT SCALE PRINTS	CHECKED RMB	6/1/2017
	QA	
TOLERANCES ARE: FRACTIONS: ± 1/64 DECIMALS: .XX ± .01 .XXX ± .003 ANGLES: ± 1/2°	MFG	
	ENGINEER JEM	6/1/2017
	APPROVED RMB	6/1/2017

The PHOENIX Company of Chicago, Inc.					
22 GREAT HILL RD., NAUGATUCK, CT 06770 WWW.PHOENIXOFCHICAGO.COM PHONE: (800) 323-9562 FAX:(630) 206-1801					
TITLE PkZ® RECEPTACLE, DIRECT SOLDER TERMINATION					
SIZE B	FSCM 58167	DWG NO 268-1021-0670	REV E	PLATING OPT. A, C	
SCALE 5 : 1	F.S.R. #	SHEET 1 OF 1			

4

3

2

1