

4

3

2

1

B

B

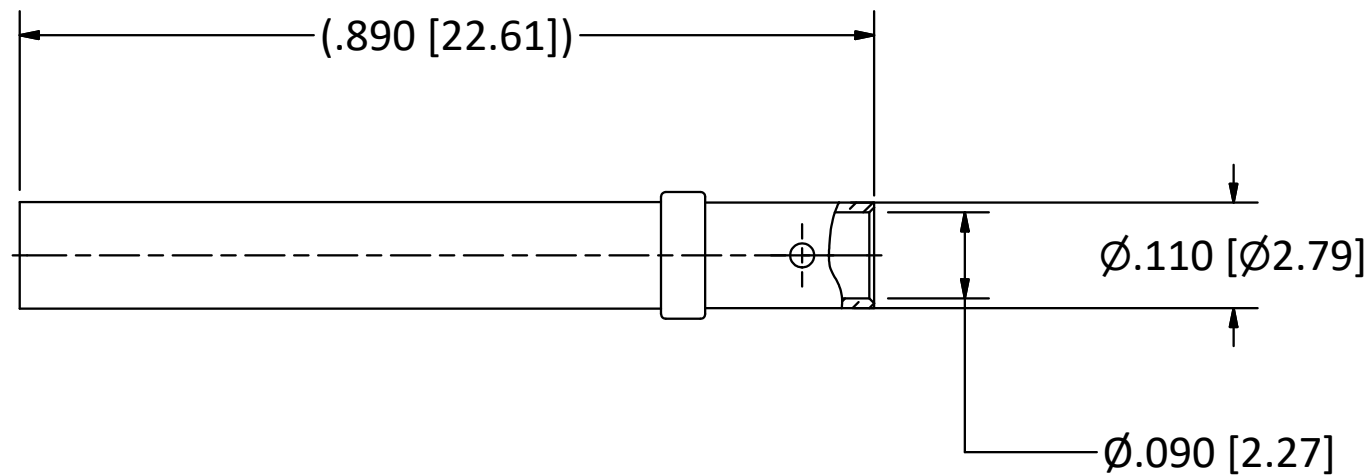

NOTES:

- 1. SPECIFICATIONS PER IDS-268.
- 2. ACCOMMODATES RG-405 (.086 SEMI-RIGID) OR EQUIVALENT FLEXIBLE CABLE.
- 3. FREQUENCY: DC TO 50 GHz.
- 4. HOUSING: ARINC 600 PLUG CONNECTOR SHELL CONTAINING SIZE 16 CAVITY (REF: MIL-DTL-83527B).
- 5. **DOES NOT MATE WITH OTHER INDUSTRY-STANDARD SIZE 16 CONTACTS.**

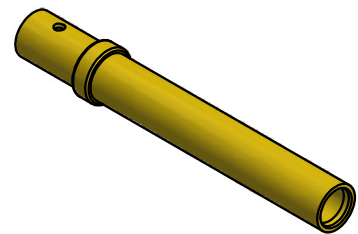

SCALE 2.5 : 1

4

3

2

1

A

A

				<p>THE INFORMATION AND DESIGNS DISCLOSED IN THIS DOCUMENT ARE CONFIDENTIAL AND/OR PROPRIETARY TO THE PHOENIX COMPANY OF CHICAGO INC. AND MAY NOT BE USED FOR MANUFACTURING, REPRODUCED, DISCLOSED TO OTHERS OR FOR ANY OTHER PURPOSE WITHOUT THE EXPRESS WRITTEN CONSENT OF THE PHOENIX COMPANY OF CHICAGO INC.</p>	<p>WARNING - THIS DOCUMENT CONTAINS TECHNICAL DATA WHOSE EXPORT IS RESTRICTED BY THE ARMS EXPORT CONTROL ACT (TITLE 22, U.S.C., SEC 2751, ET. SEQ.) OR THE EXPORT ADMINISTRATION ACT OF 1979, AS AMENDED, TITLE 50, U.S.C., APP 2401 ET SEQ. VIOLATIONS OF THESE EXPORT LAWS ARE SUBJECT TO SEVERE CRIMINAL PENALTIES. DISSEMINATE IN ACCORDANCE WITH PROVISIONS OF DOD DIRECTIVE 5230.25.</p>	<p>UNLESS OTHERWISE SPECIFIED, PHOENIX WORKMANSHIP STANDARDS APPLY DIMENSIONS IN INCHES OR (METRIC)</p> <p>DO NOT SCALE PRINTS</p> <p>TOLERANCES ARE: FRACTIONS: ± 1/64 DECIMALS: .XX ± .01 .XXX ± .003 ANGLES: ± 1/2°</p>			<table border="1"> <tr> <th>APPROVALS</th> <th>DATE</th> </tr> <tr> <td>DRAWN SPS</td> <td>5/18/18</td> </tr> <tr> <td>CHECKED JEM</td> <td>5/18/18</td> </tr> <tr> <td>QA</td> <td></td> </tr> <tr> <td>MFG</td> <td></td> </tr> <tr> <td>ENGINEER SPS</td> <td>5/18/18</td> </tr> <tr> <td>APPROVED JEM</td> <td>5/18/18</td> </tr> </table>		APPROVALS	DATE	DRAWN SPS	5/18/18	CHECKED JEM	5/18/18	QA		MFG		ENGINEER SPS	5/18/18	APPROVED JEM	5/18/18	<p>The PHOENIX Company of Chicago, Inc.</p> <p>22 GREAT HILL RD., NAUGATUCK, CT 06770 WWW.PHOENIXOFCHICAGO.COM PHONE: (800) 323-9562 FAX:(630) 206-1801</p>								
APPROVALS	DATE																																
DRAWN SPS	5/18/18																																
CHECKED JEM	5/18/18																																
QA																																	
MFG																																	
ENGINEER SPS	5/18/18																																
APPROVED JEM	5/18/18																																
<table border="1"> <tr> <th>REV</th> <th>DESCRIPTION</th> <th>DATE</th> <th>BY</th> </tr> <tr> <td>D</td> <td>PER ECN 14401</td> <td>5/22/2024</td> <td>SG</td> </tr> <tr> <td>C</td> <td>PER ECN 13692</td> <td>2/13/2020</td> <td>JEM</td> </tr> <tr> <td>B</td> <td>PER ECN 13148</td> <td>10/12/2018</td> <td>JEM</td> </tr> <tr> <td>A</td> <td>PER ECN 12941</td> <td>5/18/18</td> <td>JEM</td> </tr> </table>				REV	DESCRIPTION	DATE	BY	D	PER ECN 14401	5/22/2024	SG	C	PER ECN 13692	2/13/2020	JEM	B	PER ECN 13148	10/12/2018	JEM	A	PER ECN 12941	5/18/18	JEM				<p>TITLE</p> <p>PkZ® RECEPTACLE, DIRECT SOLDER TERMINATION</p>		<p>SIZE B</p>	<p>FSCM 58167</p>	<p>DWG NO 268-1021-0860</p>	<p>REV D</p>	<p>PLATING OPT. A, C</p>
REV	DESCRIPTION	DATE	BY																														
D	PER ECN 14401	5/22/2024	SG																														
C	PER ECN 13692	2/13/2020	JEM																														
B	PER ECN 13148	10/12/2018	JEM																														
A	PER ECN 12941	5/18/18	JEM																														
				<p>SCALE</p>		<p>F.S.R. #</p>		<p>SHEET 1 OF 1</p>																									