

CABLE ASSEMBLY PROCEDURE	
P/N	26D-002X-0860
PAGE 1 OF 2	DATE: 03/20/96
DRAWN: JEM	APPROVED: HN
FOR USE WITH RG-405 S/R CABLE	

The **PHOENIX** Company of Chicago™  
 22 GREAT HILL RD., NAUGATUCK, CT 06770  
 WWW.PHOENIXOFCHICAGO.COM  
 PHONE: (203) 729-9090 FAX: (203) 723-1794

REV	DESCRIPTION	DATE	APPR
F	PER ECN 10538	08/18/10	JEM
G	PER ECN 13653	1/27/20	JEM

FOR RG-405 S/R CABLE

STEP 1

TRIM CABLE TO DIMENSIONS SHOWN.  
 POINT END AS SHOWN.

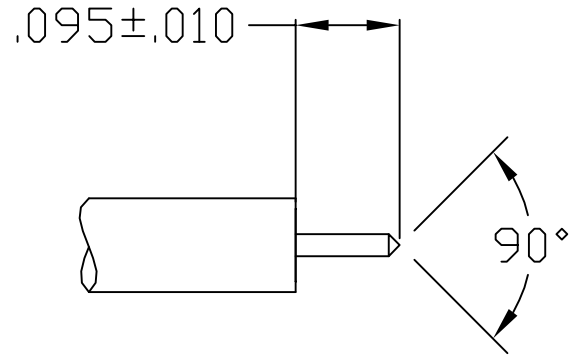

STEP 2

INSERT CABLE INTO BODY AND SOLDER  
 AS SHOWN. CLEAN SOLDER JOINT.

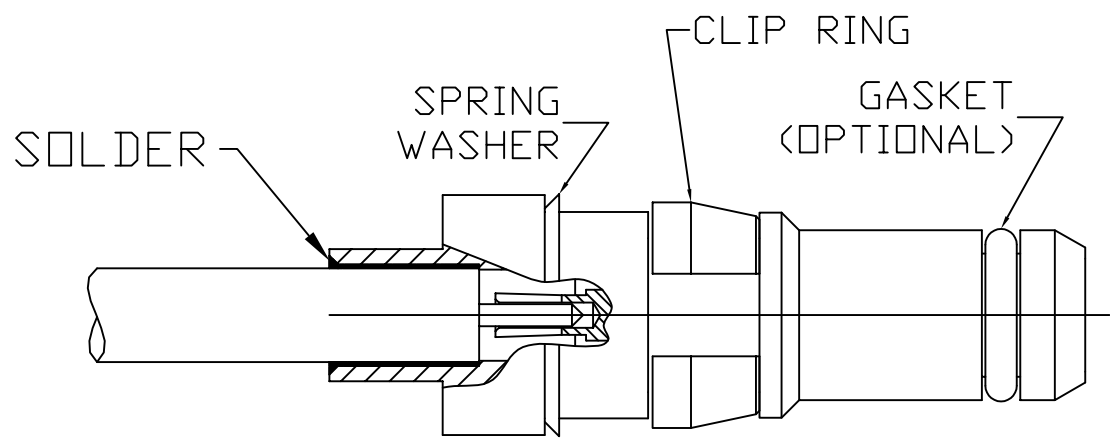

CABLE ASSEMBLY PROCEDURE	
P/N	26D-002X-0860
PAGE 2 OF 2	DATE: 04/27/06
DRAWN: EK	APPROVED: JEM
FOR USE WITH TFLEX-405 CABLE	

The **PHOENIX** Company of Chicago™  
 22 GREAT HILL RD., NAUGATUCK, CT 06770  
 WWW.PHOENIXOFCHICAGO.COM  
 PHONE: (203) 729-9090 FAX: (203) 723-1794

REV	DESCRIPTION	DATE	APPR
F	PER ECN 10538	08/18/10	JEM
G	PER ECN 13653	1/27/20	JEM

FOR USE WITH TFLEX-405

STEP 1  
 TIN DIP CABLE TO  
 DIMENSIONS SHOWN.

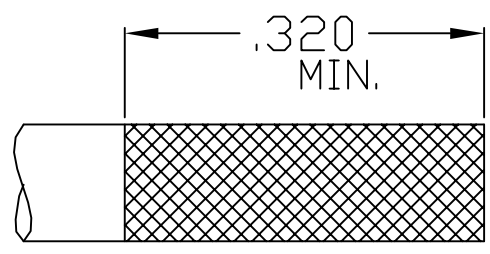

STEP 2  
 TRIM CABLE TO DIMENSIONS  
 SHOWN AND POINT  
 CENTER CONDUCTOR.

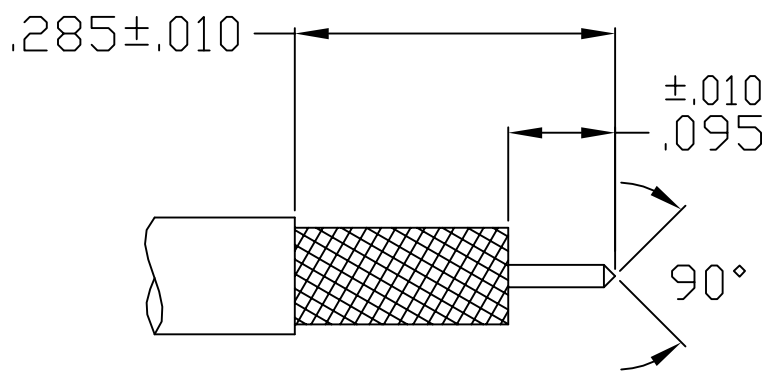

STEP 3  
 INSERT CABLE INTO BODY AND SOLDER  
 AS SHOWN. CLEAN SOLDER JOINT.

