

4

3

2

1

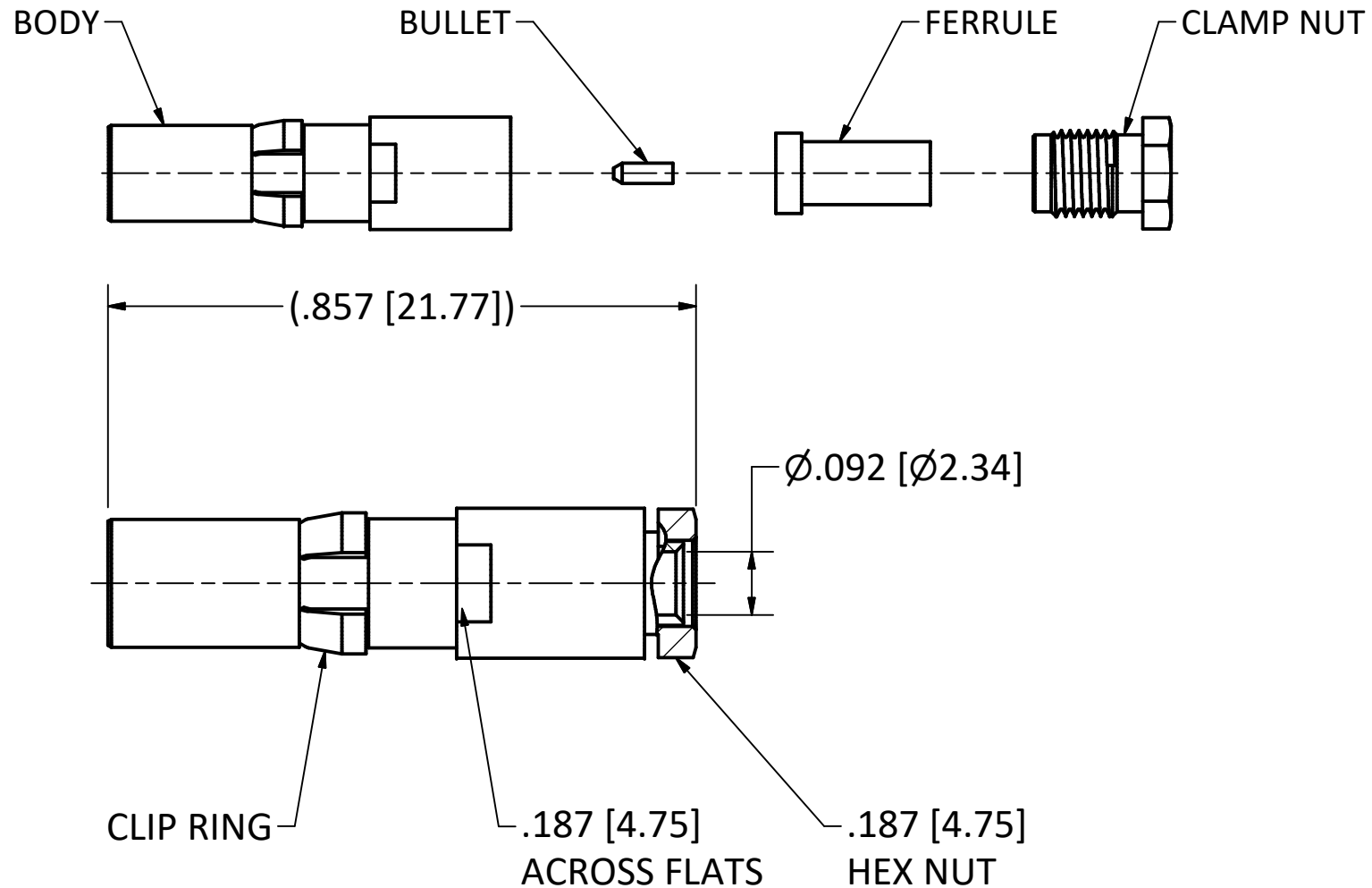

NOTES:

- 1. SPECIFICATION PER IDS-26.
  - 2. CLAMP NUT, FERRULE, AND BULLET SHIPPED LOOSE.
  - 3. ACCOMMODATES RG-405 (.086 SEMI-RIGID) OR EQUIVALENT FLEXIBLE CABLE.
- HOUSING:** DIN 41612, SIZE 8 CAVITY.

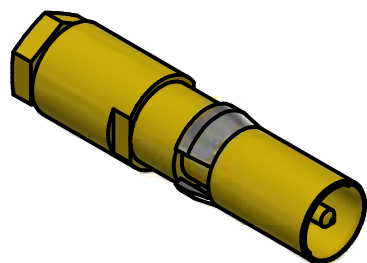

SCALE 2.5 : 1

REV.	DESCRIPTION	DATE	BY
K	ECN 13799	7/6/20	JEM
J	ECN 11001	6/22/11	JEM
H	ECN 10686	11/05/10	JEM
G	ECN 9646	11/20/08	JEM
F	ECN 7145	8/15/03	HN

This drawing embodies a proprietary design of The Phoenix Company of Chicago, Inc., Naugatuck, CT 06770. All design, manufacturing, reproduction, use, sale, and other rights regarding the same are expressly reserved. The information in this drawing may be covered completely or in part by patents and/or patents pending.

WARNING - THIS DOCUMENT CONTAINS TECHNICAL DATA WHOSE EXPORT IS RESTRICTED BY THE ARMS EXPORT CONTROL ACT (TITLE 22, U.S.C., SEC 2751, ET. SEQ.) OR THE EXPORT ADMINISTRATION ACT OF 1979, AS AMENDED, TITLE 50, U.S.C., APP 2401 ET SEQ. VIOLATIONS OF THESE EXPORT LAWS ARE SUBJECT TO SEVERE CRIMINAL PENALTIES. DISSEMINATE IN ACCORDANCE WITH PROVISIONS OF DOD DIRECTIVE 5230.25.

Filename: ver2\Autodesk Inventor Data Base\Assemblies\26 Series\26D-1030-0860-CU.idw

UNLESS OTHERWISE SPECIFIED, PHOENIX WORKMANSHIP STANDARDS APPLY DIMENSIONS IN INCHES OR (METRIC)

DO NOT SCALE PRINTS

TOLERANCES ARE:  
FRACTIONS: ± 1/64  
DECIMALS: .XX ± .01  
.XXX ± .003  
ANGLES: ± 1/2°

	APPROVALS	DATE
DRAWN	YT	8/15/2003
CHECKED	HN	8/15/2003
QA		
MFG		
ENGINEER	YT	8/15/2003
APPROVED	HN	8/15/2003

The **PHOENIX** Company of Chicago, Inc.

22 GREAT HILL RD., NAUGATUCK, CT 06770  
WWW.PHOENIXOFCHICAGO.COM  
PHONE: (800) 323-9562 FAX:(630) 206-1801

TITLE  
**PKZ® RECEPTACLE, SOLDER/CLAMP TERMINATION**

SIZE <b>B</b>	FSCM 58167	DWG NO <b>26D-1030-0860</b>	REV K	PLATING OPT. A, B, C, D
------------------	---------------	--------------------------------	----------	----------------------------

SCALE 2.5 : 1 F.S.R. # SHEET 1 OF 1

4

3

2

1