

4

3

2

1

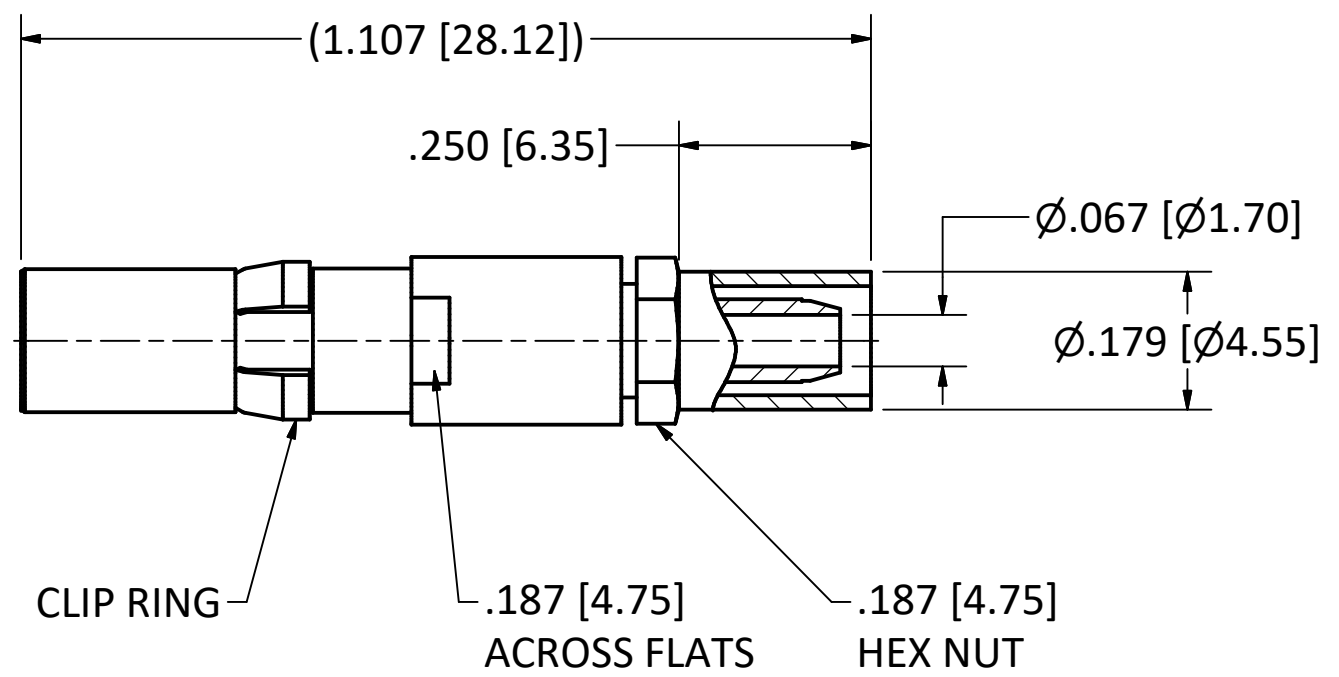
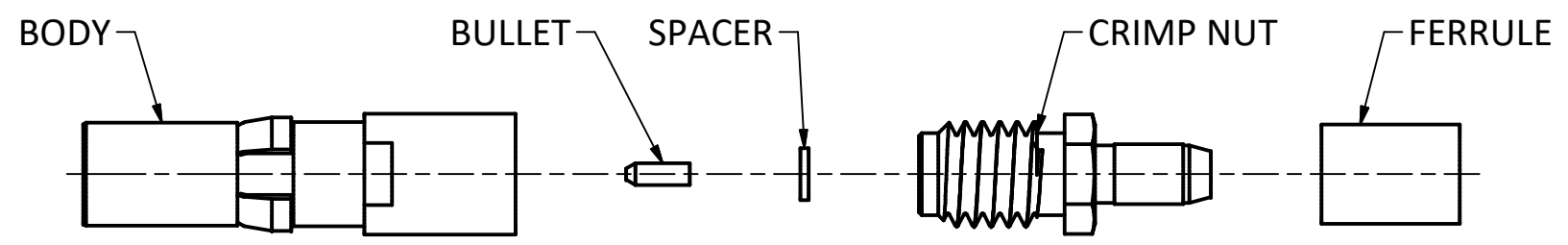

- NOTES:
1. SPECIFICATIONS PER IDS-26.
 2. BULLET, SPACER, FERRULE, AND CRIMP NUT SHIPPED LOOSE.
 3. ACCOMMODATES RG-316 DOUBLE SHIELD (M17/152) CABLE.
 4. CRIMP USING .151 HEX DIE (M22520/5-37).
- HOUSING:** DIN 41612, SIZE 8 CAVITY.

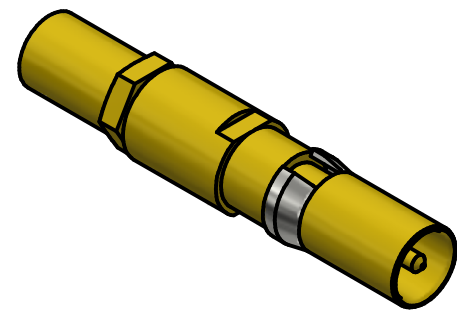

SCALE 2.5 : 1

REV.	DESCRIPTION	DATE	BY
F	ECN 13814	7/17/20	JEM
E	ECN 10705	11/10/10	JEM
D	ECN 9645	11/20/08	JEM
C	ECN 6779	10/31/02	HN
B	ECN 3894	11/3/2020	HN
A	ECN 3206	11/10/95	HN

This drawing embodies a proprietary design of The Phoenix Company of Chicago, Inc., Naugatuck, CT 06770. All design, manufacturing, reproduction, use, sale, and other rights regarding the same are expressly reserved. The information in this drawing may be covered completely or in part by patents and/or patents pending.

WARNING - THIS DOCUMENT CONTAINS TECHNICAL DATA WHOSE EXPORT IS RESTRICTED BY THE ARMS EXPORT CONTROL ACT (TITLE 22, U.S.C., SEC 2751, ET. SEQ.) OR THE EXPORT ADMINISTRATION ACT OF 1979, AS AMENDED, TITLE 50, U.S.C., APP 2401 ET SEQ. VIOLATIONS OF THESE EXPORT LAWS ARE SUBJECT TO SEVERE CRIMINAL PENALTIES. DISSEMINATE IN ACCORDANCE WITH PROVISIONS OF DOD DIRECTIVE 5230.25.

Filename: ver2\Autodesk Inventor Data Base\Assemblies\26 Series\26D-1080-2670-CU.idw		
UNLESS OTHERWISE SPECIFIED, PHOENIX WORKMANSHIP STANDARDS APPLY DIMENSIONS IN INCHES OR (METRIC) DO NOT SCALE PRINTS TOLERANCES ARE: FRACTIONS: ± 1/64 DECIMALS: .XX ± .01 .XXX ± .003 ANGLES: ± 1/2°	APPROVALS	DATE
	DRAWN EY	11/10/1995
	CHECKED HN	11/10/1995
	QA	
	MFG	
	ENGINEER JEM	11/10/1995
APPROVED HN	11/10/1995	

The PHOENIX Company of Chicago, Inc.
 22 GREAT HILL RD., NAUGATUCK, CT 06770
 WWW.PHOENIXOFCHICAGO.COM
 PHONE: (800) 323-9562 FAX:(630) 206-1801

TITLE
PkZ® RECEPTACLE, SOLDER/CRIMP TERMINATION

SIZE B	FSCM 58167	DWG NO 26D-1080-2670	REV F	PLATING OPT. A, B, C, D
SCALE 2.5 : 1		F.S.R. #	SHEET 1 OF 1	

4

3

2

1