

4

3

2

1

B

B

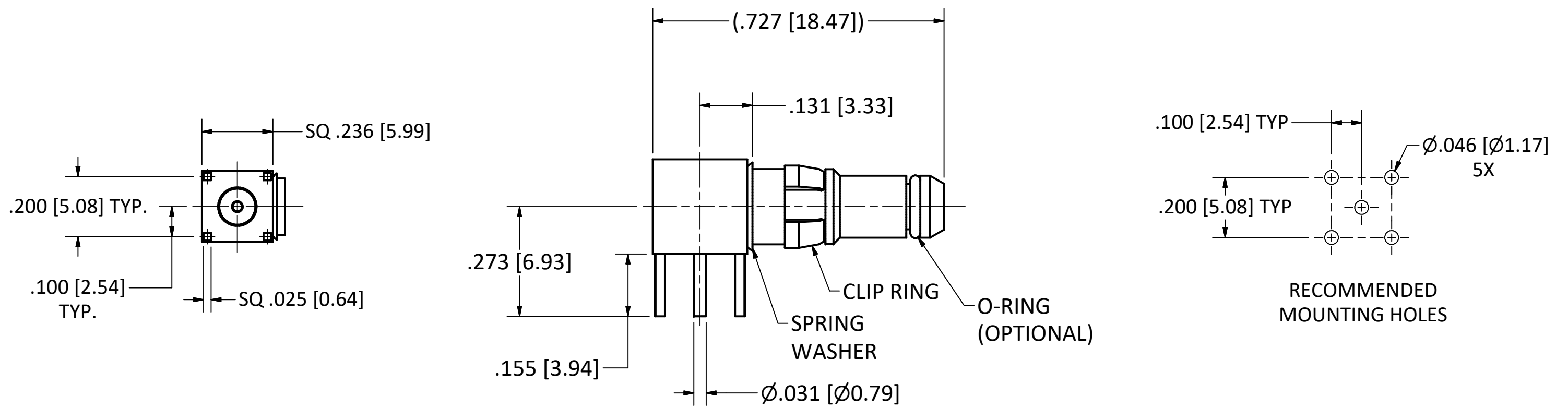

NOTES:
 1. SPECIFICATIONS PER IDS-26.
HOUSING: DIN 41612, SIZE 8 CAVITY.

PART NUMBER	O-RING OPTIONS
26D-2450-04	NONE
26D-2451-04	ENVIRONMENTAL
26D-2453-04	EMI SPRING
26D-2455-04	GROUNDING RING

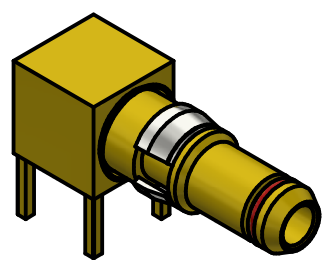

SCALE 2.5 : 1

REV	DESCRIPTION	DATE	BY
F	ECN 10988	6/9/11	JEM
E	ECN 10387	5/24/10	JEM
D	ECN 10083	11/05/09	JEM
C	ECN 8561	6/20/06	JEM
B	ECN 5696	11/29/11	HN

This drawing embodies a proprietary design of The Phoenix Company of Chicago, Inc., Naugatuck, CT 06770. All design, manufacturing, reproduction, use, sale, and other rights regarding the same are expressly reserved. The information in this drawing may be covered completely or in part by patents and/or patents pending.

WARNING - THIS DOCUMENT CONTAINS TECHNICAL DATA WHOSE EXPORT IS RESTRICTED BY THE ARMS EXPORT CONTROL ACT (TITLE 22, U.S.C., SEC 2751, ET. SEQ.) OR THE EXPORT ADMINISTRATION ACT OF 1979, AS AMENDED, TITLE 50, U.S.C., APP 2401 ET SEQ. VIOLATIONS OF THESE EXPORT LAWS ARE SUBJECT TO SEVERE CRIMINAL PENALTIES. DISSEMINATE IN ACCORDANCE WITH PROVISIONS OF DOD DIRECTIVE 5230.25.

Filename: ver2\Autodesk Inventor Data Base\Assemblies\26 Series\26D-245X-04-CU.idw

UNLESS OTHERWISE SPECIFIED, PHOENIX WORKMANSHIP STANDARDS APPLY DIMENSIONS IN INCHES OR (METRIC)	APPROVALS	DATE
DO NOT SCALE PRINTS TOLERANCES ARE: FRACTIONS: ± 1/64 DECIMALS: .XX ± .01 .XXX ± .003 ANGLES: ± 1/2°	DRAWN	9/26/1995
	CHECKED	9/26/1995
	QA	
	MFG	
	ENGINEER	9/26/1995
	APPROVED	9/26/1995

The PHOENIX Company of Chicago, Inc.
 22 GREAT HILL RD., NAUGATUCK, CT 06770
 WWW.PHOENIXOFCHICAGO.COM
 PHONE: (800) 323-9562 FAX:(630) 206-1801

TITLE
PkZ® RIGHT ANGLE PLUG, PRINTED CIRCUIT MOUNT

SIZE	FSCM	DWG NO	REV	PLATING OPT.
B	58167	26D-245X-04	F	A, B, C, D

SCALE 2.5 : 1 F.S.R. # SHEET 1 OF 1

4

3

2

1

A

A