

4

3

2

1

FERRULE

BODY

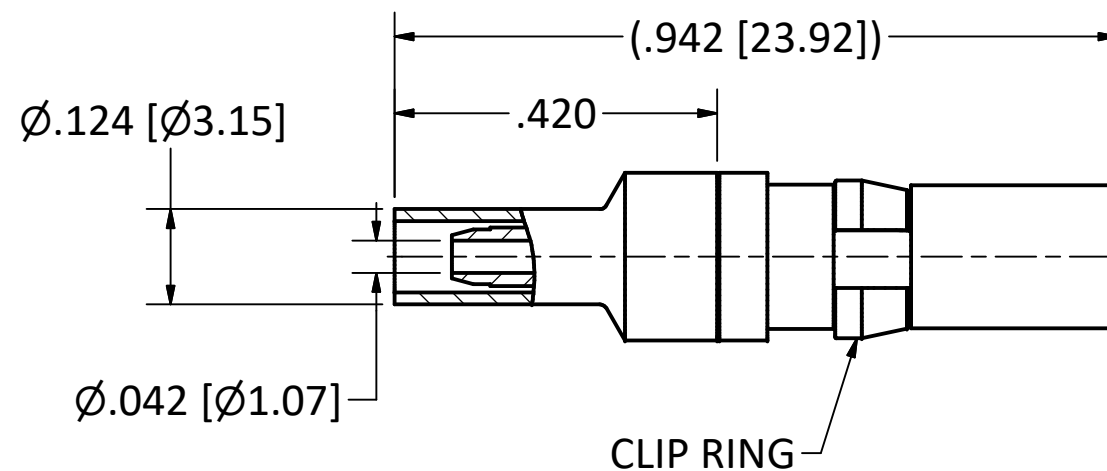
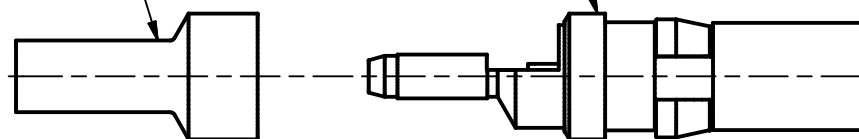

NOTES:

- 1. SPECIFICATIONS PER IDS-28.
 - 2. FERRULE SHIPPED LOOSE.
 - 3. ACCOMMODATES RG-178, RG-196, OR 1.37mm CABLE.
 - 4. CRIMP USING .105 HEX DIE (M22520/5-03).
- HOUSING:** DIN 41612, SIZE 8 CAVITY.

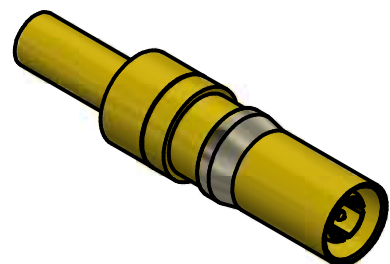

SCALE 2.5 : 1

<p>This drawing embodies a proprietary design of The Phoenix Company of Chicago, Inc., Naugatuck, CT 06770. All design, manufacturing, reproduction, use, sale, and other rights regarding the same are expressly reserved. The information in this drawing may be covered completely or in part by patents and/or patents pending.</p>				<p>WARNING - THIS DOCUMENT CONTAINS TECHNICAL DATA WHOSE EXPORT IS RESTRICTED BY THE ARMS EXPORT CONTROL ACT (TITLE 22, U.S.C., SEC 2751, ET. SEQ.) OR THE EXPORT ADMINISTRATION ACT OF 1979, AS AMENDED, TITLE 50, U.S.C., APP 2401 ET SEQ. VIOLATIONS OF THESE EXPORT LAWS ARE SUBJECT TO SEVERE CRIMINAL PENALTIES. DISSEMINATE IN ACCORDANCE WITH PROVISIONS OF DOD DIRECTIVE 5230.25.</p>		<p>Filename: ver2\Autodesk Inventor Data Base\Assemblies\28 Series\28-0080-0400-CU.idw</p>		<p>The PHOENIX Company of Chicago, Inc. 22 GREAT HILL RD., NAUGATUCK, CT 06770 WWW.PHOENIXOFCHICAGO.COM PHONE: (800) 323-9562 FAX:(630) 206-1801</p>											
						<p>UNLESS OTHERWISE SPECIFIED, PHOENIX WORKMANSHIP STANDARDS APPLY DIMENSIONS IN INCHES OR (METRIC)</p> <p>DO NOT SCALE PRINTS</p> <p>TOLERANCES ARE: FRACTIONS: ± 1/64 DECIMALS: .XX ± .01 .XXX ± .003 ANGLES: ± 1/2°</p>				<table border="1"> <thead> <tr> <th>APPROVALS</th> <th>DATE</th> </tr> </thead> <tbody> <tr> <td>DRAWN JEM</td> <td>6/9/1997</td> </tr> <tr> <td>CHECKED HN</td> <td>6/9/1997</td> </tr> <tr> <td>QA</td> <td></td> </tr> <tr> <td>MFG</td> <td></td> </tr> <tr> <td>ENGINEER HN</td> <td>6/9/1997</td> </tr> <tr> <td>APPROVED JEM</td> <td>6/9/1997</td> </tr> </tbody> </table>		APPROVALS	DATE	DRAWN JEM	6/9/1997	CHECKED HN	6/9/1997	QA	
APPROVALS	DATE																		
DRAWN JEM	6/9/1997																		
CHECKED HN	6/9/1997																		
QA																			
MFG																			
ENGINEER HN	6/9/1997																		
APPROVED JEM	6/9/1997																		
<table border="1"> <thead> <tr> <th>REV.</th> <th>DESCRIPTION</th> <th>DATE</th> <th>BY</th> </tr> </thead> <tbody> <tr> <td>A</td> <td>ECN 3927</td> <td>06/09/97</td> <td>HN</td> </tr> </tbody> </table>		REV.	DESCRIPTION	DATE	BY	A	ECN 3927	06/09/97	HN	<table border="1"> <tr> <td>SIZE B</td> <td>FSCM 58167</td> <td>DWG NO 28-0080-0400</td> <td>REV A</td> <td>PLATING OPT. A, B</td> </tr> </table>		SIZE B	FSCM 58167	DWG NO 28-0080-0400	REV A	PLATING OPT. A, B			
REV.	DESCRIPTION	DATE	BY																
A	ECN 3927	06/09/97	HN																
SIZE B	FSCM 58167	DWG NO 28-0080-0400	REV A	PLATING OPT. A, B															
		<p>SCALE 3 : 1</p>		<p>F.S.R. #</p>		<p>SHEET 1 OF 1</p>													

4

3

2

1