

4

3

2

1

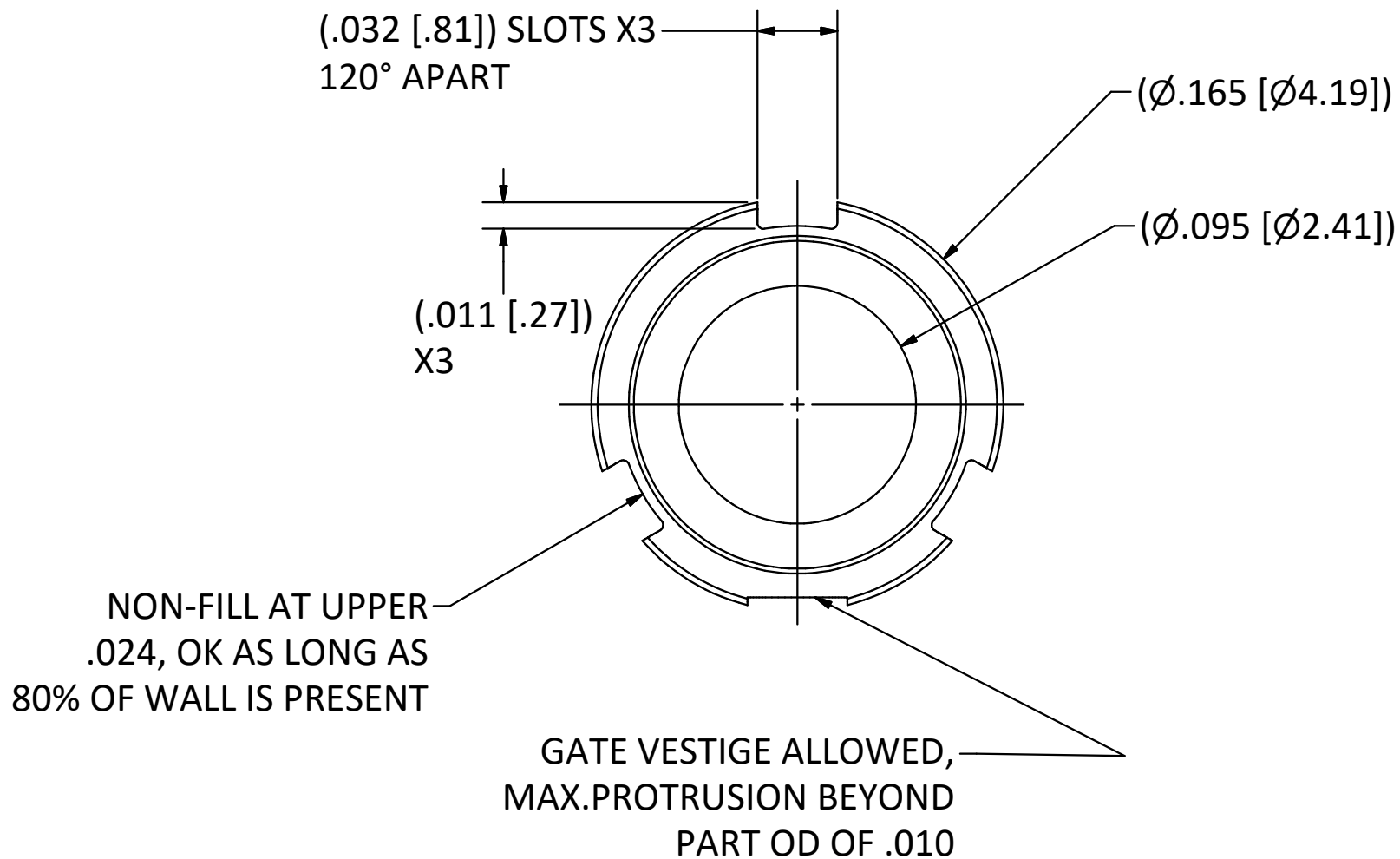
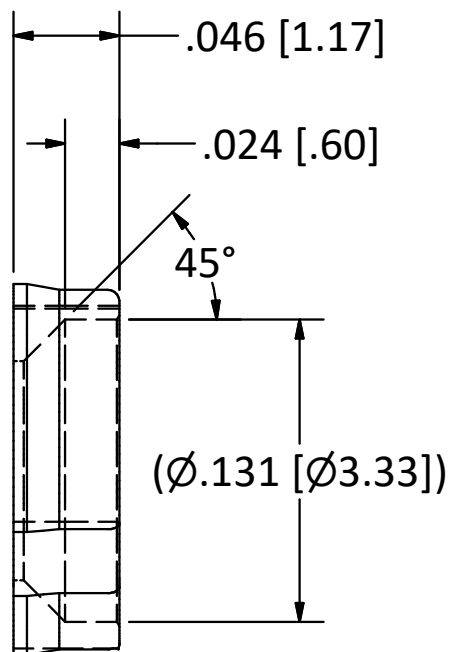

NOTES:
 1. MATERIAL: ENTEC VECTRA E130 LCP OR XYDAR G930 LCP. COLOR: BLACK.

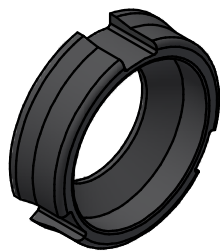

B	PER ECN 12478	03/17/17	RMB
A	PER ECN 12356	08/30/16	RMB
REV	DESC	DATE	BY

This drawing embodies a proprietary design of The Phoenix Company of Chicago, Inc., Naugatuck, CT 06770. All design, manufacturing, reproduction, use, sale, and other rights regarding the same are expressly reserved. The information in this drawing may be covered completely or in part by patents and/or patents pending.

WARNING - THIS DOCUMENT CONTAINS TECHNICAL DATA WHOSE EXPORT IS RESTRICTED BY THE ARMS EXPORT CONTROL ACT (TITLE 22, U.S.C., SEC 2751, ET. SEQ.) OR THE EXPORT ADMINISTRATION ACT OF 1979, AS AMENDED, TITLE 50, U.S.C., APP 2401 ET SEQ. VIOLATIONS OF THESE EXPORT LAWS ARE SUBJECT TO SEVERE CRIMINAL PENALTIES. DISSEMINATE IN ACCORDANCE WITH PROVISIONS OF DOD DIRECTIVE 5230.25.

Filename: B_C_Size_Formats.idw

UNLESS OTHERWISE SPECIFIED, PHOENIX WORKMANSHIP STANDARDS APPLY DIMENSIONS IN INCHES OR (METRIC)

DO NOT SCALE PRINTS
 TOLERANCES ARE:
 FRACTIONS: ± 1/64
 DECIMALS: .XX ± .01
 .XXX ± .003
 ANGLES: ± 1/2°

32√

APPROVALS	DATE
DRAWN JEM	8/12/2016
CHECKED RMB	8/12/2016
QA	
MFG	
ENGINEER JEM	8/12/2016
APPROVED RMB	8/12/2016

The **PHOENIX** Company of Chicago, Inc.

22 GREAT HILL RD., NAUGATUCK, CT 06770
 WWW.PHOENIXOFCHICAGO.COM
 PHONE: (800) 323-9562 FAX:(630) 206-1801

TITLE STABILIZING RING			
SIZE B	FSCM 58167	DWG NO 56-00097	REV PLATING OPT.
SCALE 15	F.S.R. #	SHEET 2 OF 2	

4

3

2

1