

CABLE ASSEMBLY PROCEDURE		PALEO CONNECTOR 22 GREAT HILL ROAD, NAUGATUCK, CT. 06770 PHONE: (203) 729-9090 FAX: (203) 723-1794	REV	DESCRIPTION	DATE	APPR
P/N	56-0020-0001		B	PER ECN 7283	02/16/04	HN
PAGE 1 OF 1	DATE: 02/16/04		C	PER ECN 7793	01/20/05	JEM
DRAWN: EK	APPROVED: HN		D	PER ECN 10427	06/21/10	JEM
FOR USE #16 AWG (10 AMP) WIRE						

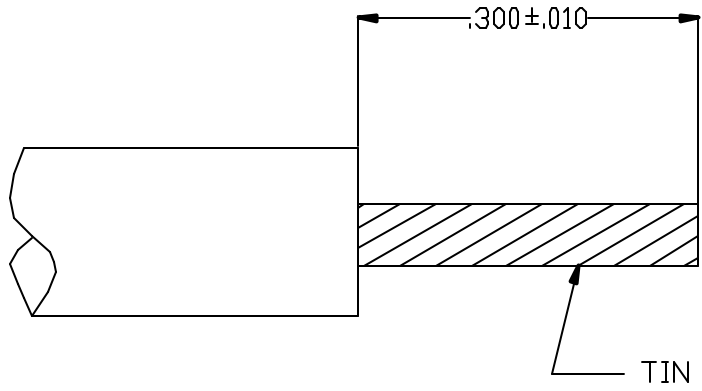

STEP 1
 TRIM WIRE TO DIMENSIONS SHOWN.
 TIN CENTER CONDUCTOR.

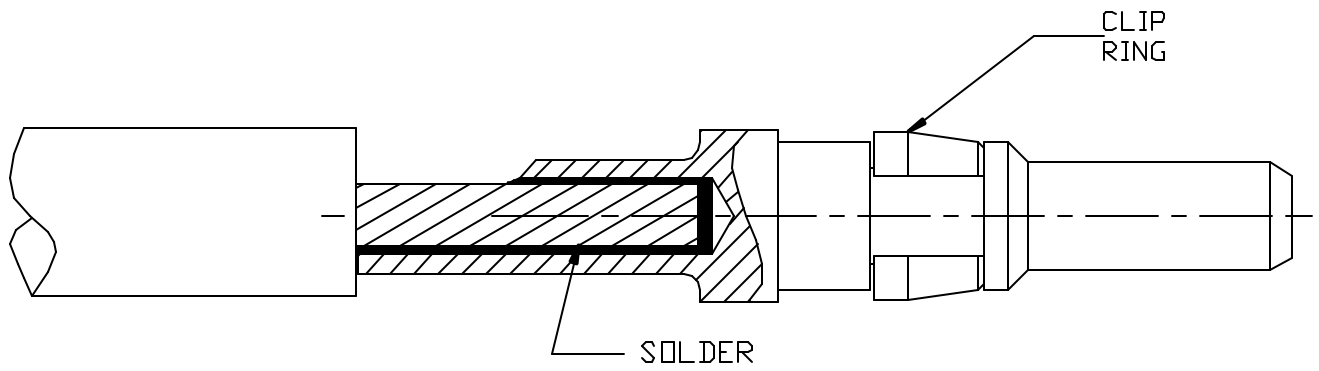

STEP 2
 SOLDER WIRE TO THE BODY AS SHOWN.
 CLEAN AND INSPECT SOLDER JOINT.