

4

3

2

1

CLAMP NUT

BODY

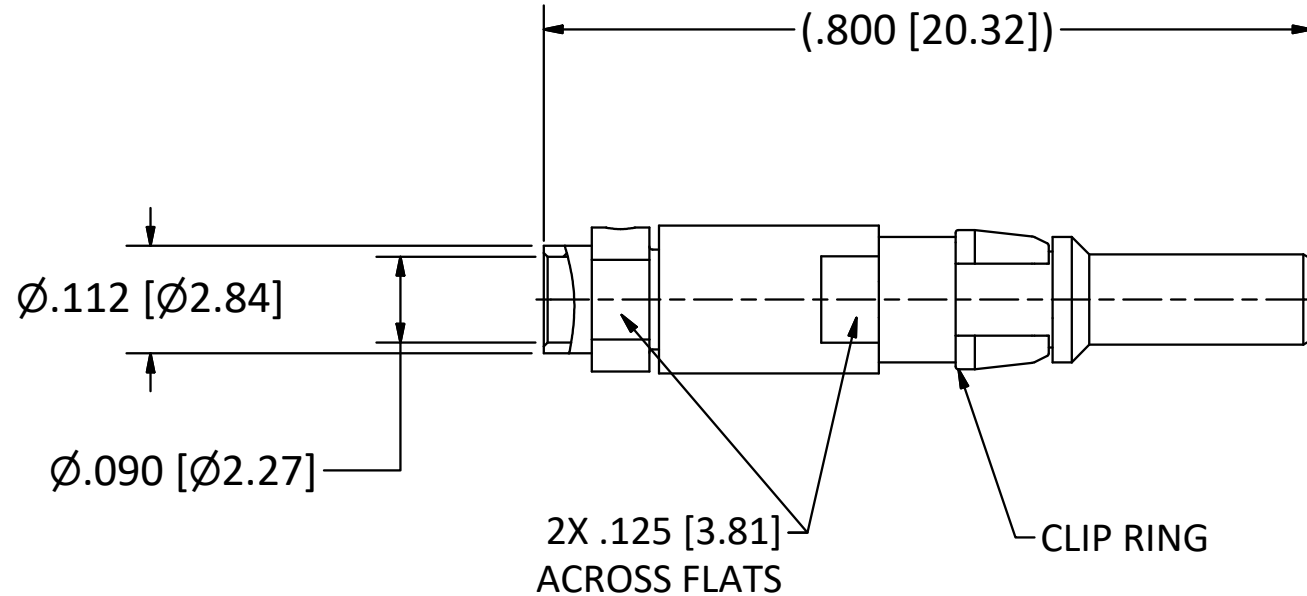

NOTES:

- 1. SPECIFICATIONS PER IDS - 56A.
- 2. CLAMP NUT SHIPPED LOOSE.
- 3. ACCOMMODATES RG-405 (.086 SEMI-RIGID) OR EQUIVALENT FLEXIBLE CABLE.
- 4. FREQUENCY: DC TO 50 GHz.

HOUSING: BENDIX LRM AND D-SUBMINIATURE HD, SIZE 12 CAVITY.

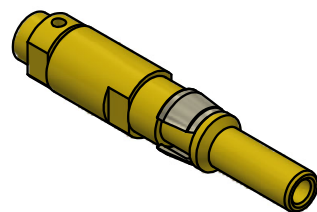

SCALE 2.5 : 1

REV.	DESCRIPTION	DATE	BY
G	PER ECN 14107	3/4/22	P.H
F	PER ECN 13746	4/16/20	JEM
E	PER ECN 13553	11/21/19	BGW
D	PER ECN 12997	6/20/18	BH

THE INFORMATION AND DESIGNS DISCLOSED IN THIS DOCUMENT ARE CONFIDENTIAL AND/OR PROPRIETARY TO THE PHOENIX COMPANY OF CHICAGO INC. AND MAY NOT BE USED FOR MANUFACTURING, REPRODUCED, DISCLOSED TO OTHERS OR FOR ANY OTHER PURPOSE WITHOUT THE EXPRESS WRITTEN CONSENT OF THE PHOENIX COMPANY OF CHICAGO INC.

WARNING - THIS DOCUMENT CONTAINS TECHNICAL DATA WHOSE EXPORT IS RESTRICTED BY THE ARMS EXPORT CONTROL ACT (TITLE 22, U.S.C., SEC 2751, ET. SEQ.) OR THE EXPORT ADMINISTRATION ACT OF 1979, AS AMENDED, TITLE 50, U.S.C., APP 2401 ET SEQ. VIOLATIONS OF THESE EXPORT LAWS ARE SUBJECT TO SEVERE CRIMINAL PENALTIES. DISSEMINATE IN ACCORDANCE WITH PROVISIONS OF DOD DIRECTIVE 5230.25.

Filename: gs from server2\Autodesk Inventor Data Base\Assemblies\56 Series\56-0302-0866-CU.idw

UNLESS OTHERWISE SPECIFIED, PHOENIX WORKMANSHIP STANDARDS APPLY DIMENSIONS IN INCHES OR (METRIC)

DO NOT SCALE PRINTS

TOLERANCES ARE:
FRACTIONS: ± 1/64
DECIMALS: .XX ± .01
.XXX ± .003
ANGLES: ± 1/2°

32

APPROVALS	DATE
DRAWN EK	4/24/09
CHECKED JEM	4/24/09
QA	
MFG	
ENGINEER EK	4/24/09
APPROVED JEM	4/24/09

The **PHOENIX** Company of Chicago, Inc.

22 GREAT HILL RD., NAUGATUCK, CT 06770
WWW.PHOENIXOFCHICAGO.COM
PHONE: (800) 323-9562 FAX:(630) 206-1801

TITLE
PKZ® PLUG, SOLDER/CLAMP TERMINATION

SIZE B	FSCM 58167	DWG NO 56-0302-0866	REV G	PLATING OPT. A, C
SCALE		F.S.R. #	SHEET 1 OF 1	

4

3

2

1