

4

3

2

1

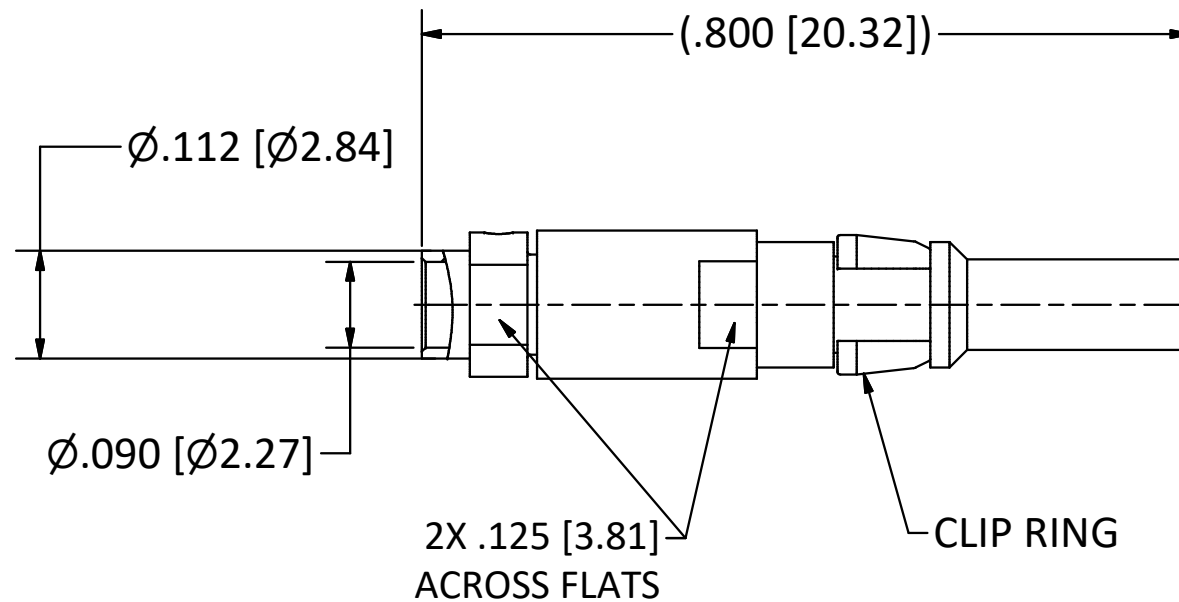
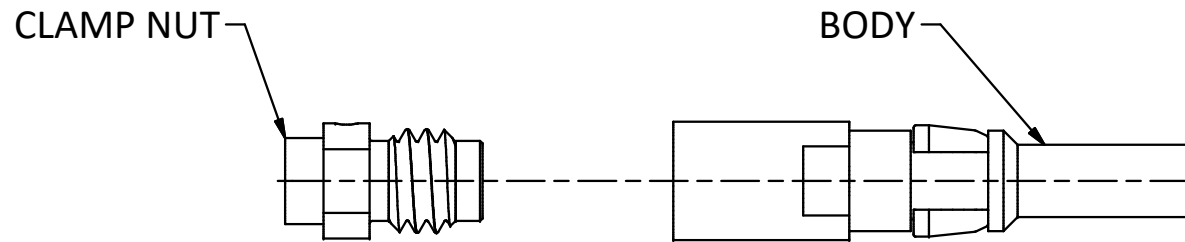

NOTES:

- 1. SPECIFICATIONS PER IDS - 56A.
 - 2. CLAMP NUT SHIPPED LOOSE.
 - 3. ACCOMMODATES RG-405 (.086 SEMI-RIGID) OR EQUIVALENT FLEXIBLE CABLE.
- HOUSING:** CUSTOM AND BENDIX LRM, SIZE 12 CAVITY.

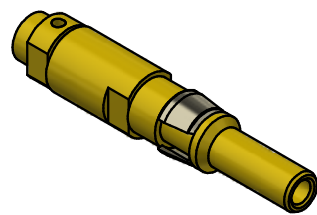

SCALE 2.5 : 1

REV.	DESCRIPTION	DATE	BY
G	PER ECN 14107	3/4/22	A.P
F	PER ECN 13553	04/16/21	BGW
E	PER ECN 12997	11/21/19	BH
D	PER ECN 12554	06/20/18	RMB
C	PER ECN 12256	06/20/17	JEM

This drawing embodies a proprietary design of The Phoenix Company of Chicago, Inc., Naugatuck, CT 06770. All design, manufacturing, reproduction, use, sale, and other rights regarding the same are expressly reserved. The information in this drawing may be covered completely or in part by patents and/or patents pending.

WARNING - THIS DOCUMENT CONTAINS TECHNICAL DATA WHOSE EXPORT IS RESTRICTED BY THE ARMS EXPORT CONTROL ACT (TITLE 22, U.S.C., SEC 2751, ET. SEQ.) OR THE EXPORT ADMINISTRATION ACT OF 1979, AS AMENDED, TITLE 50, U.S.C., APP 2401 ET SEQ. VIOLATIONS OF THESE EXPORT LAWS ARE SUBJECT TO SEVERE CRIMINAL PENALTIES. DISSEMINATE IN ACCORDANCE WITH PROVISIONS OF DOD DIRECTIVE 5230.25.

Filename: ver2\Autodesk Inventor Data Base\Assemblies\56 Series\56-0302-0866-CU.idw

UNLESS OTHERWISE SPECIFIED, PHOENIX WORKMANSHIP STANDARDS APPLY DIMENSIONS IN INCHES OR (METRIC)

DO NOT SCALE PRINTS
TOLERANCES ARE:
FRACTIONS: ± 1/64
DECIMALS: .XX ± .01
.XXX ± .003
ANGLES: ± 1/2°



APPROVALS	DATE
DRAWN EK	4/24/2009
CHECKED JEM	4/24/2009
QA	
MFG	
ENGINEER EK	4/24/2009
APPROVED JEM	4/24/2009

The **PHOENIX** Company of Chicago, Inc.

22 GREAT HILL RD., NAUGATUCK, CT 06770
WWW.PHOENIXOFCHICAGO.COM
PHONE: (800) 323-9562 FAX:(630) 206-1801

TITLE
PKZ® PLUG, SOLDER/CLAMP TERMINATION

SIZE	FSCM	DWG NO	REV	PLATING OPT.
B	58167	56-0302-0866	G	A, C
SCALE	5 : 1	F.S.R. #	SHEET 1	OF 1

4

3

2

1