

4

3

2

1

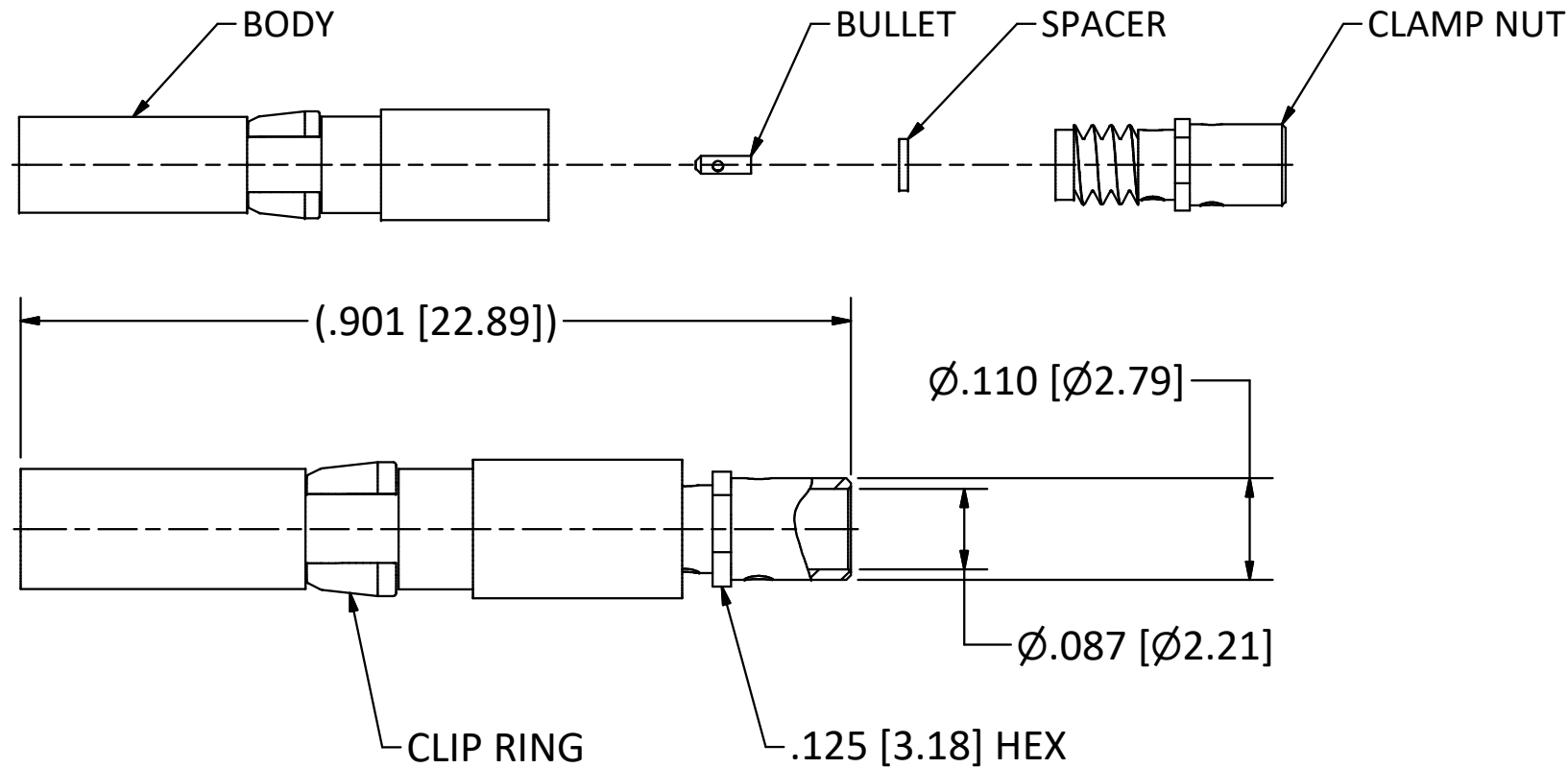

NOTES:

- 1. SPECIFICATIONS PER IDS-56.
  - 2. BULLET, CLAMP NUT, AND SPACER SHIPPED LOOSE.
  - 3. ACCOMMODATES MICRO-COAX UHQ080D CABLE.
- HOUSING:** CUSTOM AND BENDIX LRM, SIZE 12 CAVITY.

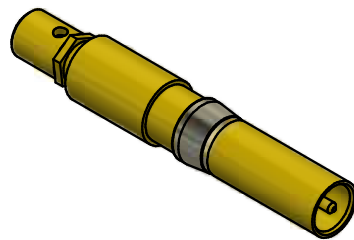

SCALE 2.5 : 1

E	PER ECN 8156	8/24/05	JM
D	PER ECN 8146	8/18/05	JM
C	PER ECN 7244	1/9/04	HN
B	PER ECN 5035	4/27/99	HN
A	REL ECN 4782	1/11/99	HN
REV	DESCRIPTION	DATE	BY

This drawing embodies a proprietary design of The Phoenix Company of Chicago, Inc., Naugatuck, CT 06770. All design, manufacturing, reproduction, use, sale, and other rights regarding the same are expressly reserved. The information in this drawing may be covered completely or in part by patents and/or patents pending.

WARNING - THIS DOCUMENT CONTAINS TECHNICAL DATA WHOSE EXPORT IS RESTRICTED BY THE ARMS EXPORT CONTROL ACT (TITLE 22, U.S.C., SEC 2751, ET. SEQ.) OR THE EXPORT ADMINISTRATION ACT OF 1979, AS AMENDED, TITLE 50, U.S.C., APP 2401 ET SEQ. VIOLATIONS OF THESE EXPORT LAWS ARE SUBJECT TO SEVERE CRIMINAL PENALTIES. DISSEMINATE IN ACCORDANCE WITH PROVISIONS OF DOD DIRECTIVE 5230.25.

Filename: \\Autodesk Inventor Data Base\Assemblies\78 Series\78-1080-0670-CU-Layout for C Sized Drawing.idw

UNLESS OTHERWISE SPECIFIED, PHOENIX WORKMANSHIP STANDARDS APPLY DIMENSIONS IN INCHES OR (METRIC)

DO NOT SCALE PRINTS  
TOLERANCES ARE:  
FRACTIONS: ± 1/64  
DECIMALS: .XX ± .01  
.XXX ± .003  
ANGLES: ± 1/2°

$\sqrt[32]{}$

	APPROVALS	DATE
DRAWN	JEM	11/10/1998
CHECKED	HN	11/10/1998
QA		
MFG		
ENGINEER	JEM	11/10/1998
APPROVED	HN	11/10/1998

The **PHOENIX** Company of Chicago, Inc.

22 GREAT HILL RD., NAUGATUCK, CT 06770  
WWW.PHOENIXOFCHICAGO.COM  
PHONE: (800) 323-9562 FAX:(630) 206-1801

TITLE  
**PKZ® RECEPTACLE, SOLDER/CLAMP TERMINATION**

SIZE	FSCM	DWG NO	REV	PLATING OPT.
<b>B</b>	58167	<b>56-1302-0473</b>	<b>E</b>	<b>A</b>
SCALE	5 : 1	F.S.R. #	SHEET 1	OF 1

4

3

2

1