

4

3

2

1

B

B

RECOMMENDED MOUNTING HOLES

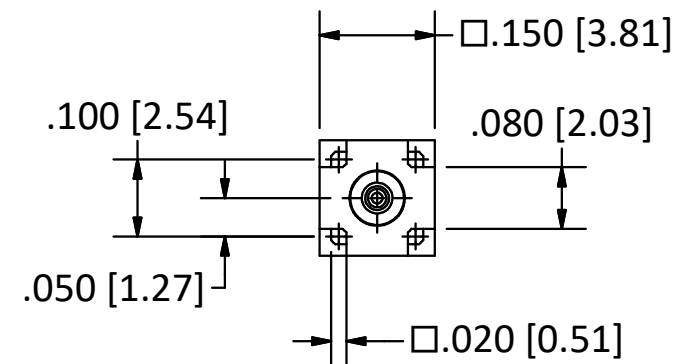
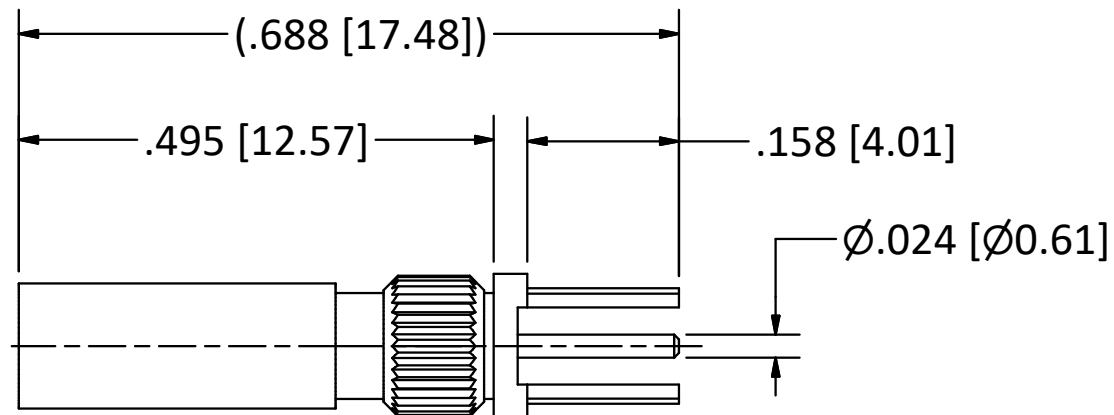
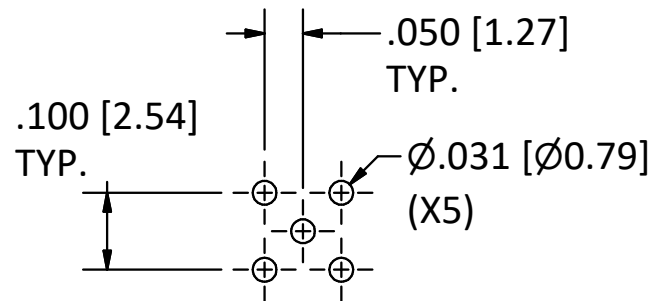

- NOTES:
 1. SPECIFICATIONS PER IDS-56AJ.
 2. MAGNETISM: <1.00000 mu.
HOUSING: CUSTOM, SIZE 12 CAVITY.

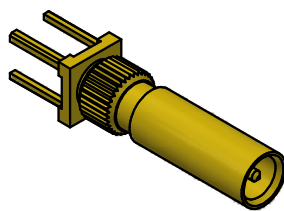

SCALE 2.5: 1

4

3

2

1

A

A

				THE INFORMATION AND DESIGNS DISCLOSED IN THIS DOCUMENT ARE CONFIDENTIAL AND/OR PROPRIETARY TO THE PHOENIX COMPANY OF CHICAGO INC. AND MAY NOT BE USED FOR MANUFACTURING, REPRODUCED, DISCLOSED TO OTHERS OR FOR ANY OTHER PURPOSE WITHOUT THE EXPRESS WRITTEN CONSENT OF THE PHOENIX COMPANY OF CHICAGO INC.		WARNING - THIS DOCUMENT CONTAINS TECHNICAL DATA WHOSE EXPORT IS RESTRICTED BY THE ARMS EXPORT CONTROL ACT (TITLE 22, U.S.C., SEC 2751, ET. SEQ.) OR THE EXPORT ADMINISTRATION ACT OF 1979, AS AMENDED, TITLE 50, U.S.C., APP 2401 ET SEQ. VIOLATIONS OF THESE EXPORT LAWS ARE SUBJECT TO SEVERE CRIMINAL PENALTIES. DISSEMINATE IN ACCORDANCE WITH PROVISIONS OF DOD DIRECTIVE 5230.25.		Filename: ver2\Autodesk Inventor Data Base\Assemblies\56 Series\56-1450-04J-CU.idw		The PHOENIX Company of Chicago, Inc. 22 GREAT HILL RD., NAUGATUCK, CT 06770 WWW.PHOENIXOFCHICAGO.COM PHONE: (800) 323-9562 FAX:(630) 206-1801			
				UNLESS OTHERWISE SPECIFIED, PHOENIX WORKMANSHIP STANDARDS APPLY DIMENSIONS IN INCHES OR (METRIC)		DO NOT SCALE PRINTS		TOLERANCES ARE: FRACTIONS: ± 1/64 DECIMALS: .XX ± .01 .XXX ± .003 ANGLES: ± 1/2°		APPROVALS DATE DRAWN R.M.BRADLEY 2/27/2014 CHECKED QA MFG ENGINEER R.M.BRADLEY 2/27/2014 APPROVED		TITLE PkZ® STRAIGHT RECEPTACLE, PRINTED CIRCUIT MOUNT	
B	PER ECN# 12454	2/15/2017	R.M.B	SIZE B FSCM 58167 DWG NO 56-1450-04J		REV A PLATING OPT.		SCALE F.S.R. #		SHEET 1 OF 1			
A	ECN# 1863, RELEASE FSR# 10798	11/18/2014	R.M.B										
REV.	DESCRIPTION	DATE	BY										