

4

3

2

1

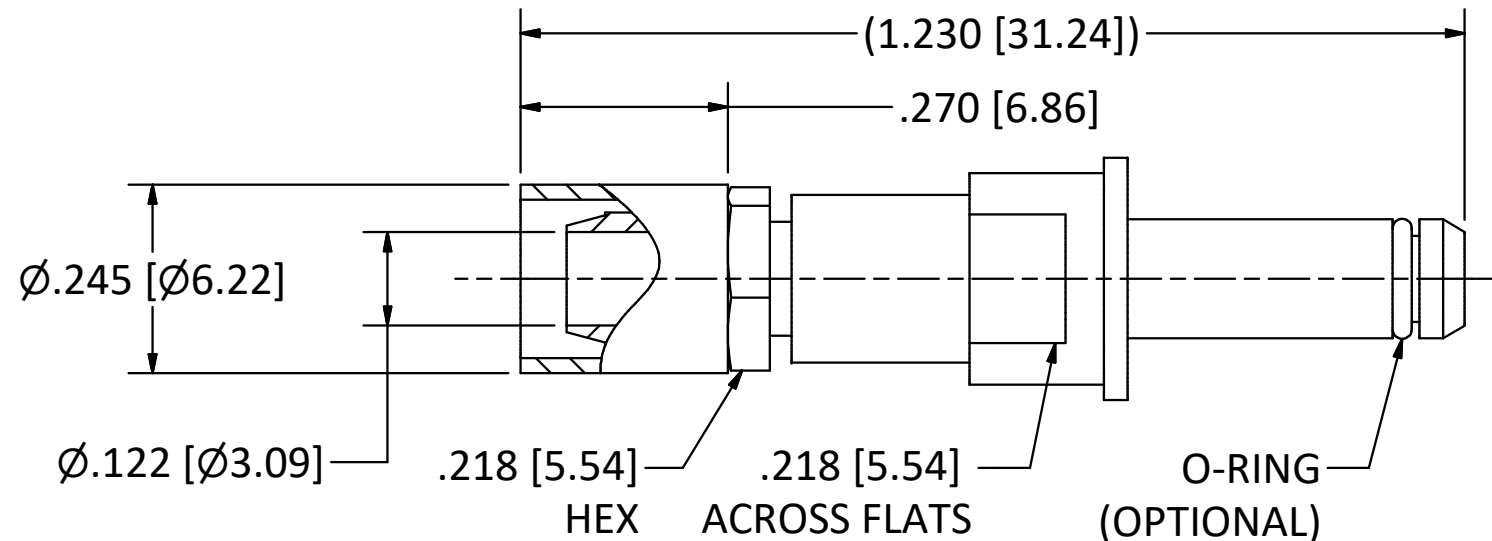
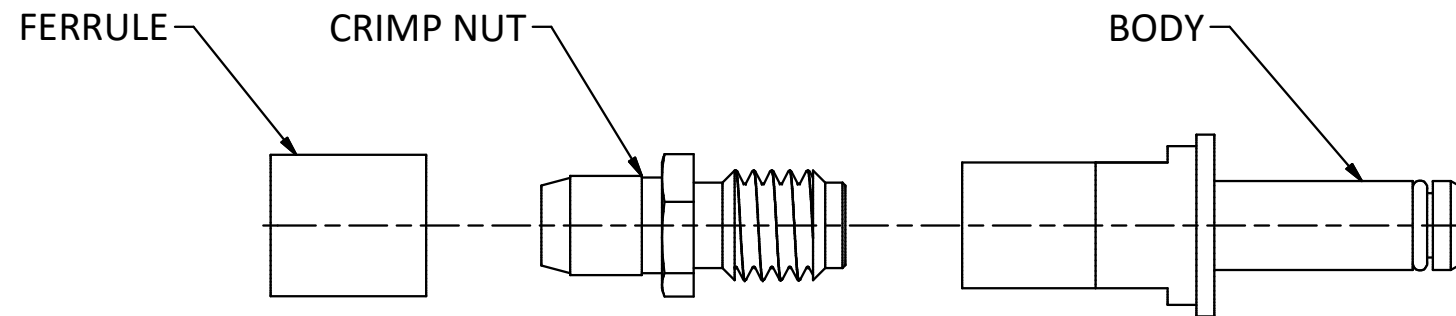

NOTES:

- 1. SPECIFICATIONS PER IDS-68.
- 2. CRIMP NUT AND FERRULE SHIPPED LOOSE.
- 3. ACCOMMODATES RG-58, RG-141, OR RG-303 CABLE.
- 4. CRIMP USING .218 HEX DIE (M22520-5/05).

HOUSING: ARINC 600 CONNECTOR PER MIL-C-83527/3, SIZE 8 CAVITY.

PART NUMBER	O-RING OPTIONS
68-0080-1200	NONE
68-0081-1200	ENVIRONMENTAL
68-0082-1200	ENVIRONMENTAL & STABILIZING

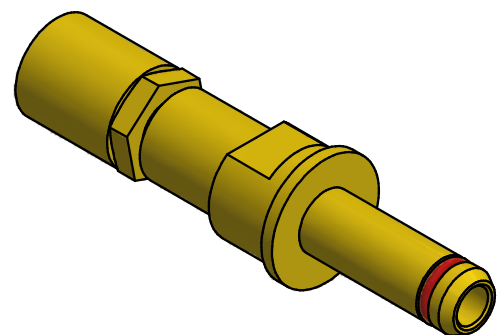

SCALE 2.5 : 1

REV.	DESCRIPTION	DATE	BY
C	PER ECN 13431	7/23/19	JEM
B	PER ECN 12694	11/03/17	JEM
A	PER ECN 12230	08/17/15	RMB

This drawing embodies a proprietary design of The Phoenix Company of Chicago, Inc., Naugatuck, CT 06770. All design, manufacturing, reproduction, use, sale, and other rights regarding the same are expressly reserved. The information in this drawing may be covered completely or in part by patents and/or patents pending.

WARNING - THIS DOCUMENT CONTAINS TECHNICAL DATA WHOSE EXPORT IS RESTRICTED BY THE ARMS EXPORT CONTROL ACT (TITLE 22, U.S.C., SEC 2751, ET. SEQ.) OR THE EXPORT ADMINISTRATION ACT OF 1979, AS AMENDED, TITLE 50, U.S.C., APP 2401 ET SEQ. VIOLATIONS OF THESE EXPORT LAWS ARE SUBJECT TO SEVERE CRIMINAL PENALTIES. DISSEMINATE IN ACCORDANCE WITH PROVISIONS OF DOD DIRECTIVE 5230.25.

Filename: ver2\Autodesk Inventor Data Base\Assemblies\68 Series\68-008X-1200-CU.idw

UNLESS OTHERWISE SPECIFIED, PHOENIX WORKMANSHIP STANDARDS APPLY DIMENSIONS IN INCHES OR (METRIC)

DO NOT SCALE PRINTS
TOLERANCES ARE:
FRACTIONS: ± 1/64
DECIMALS: .XX ± .01
.XXX ± .003
ANGLES: ± 1/2°



APPROVALS	DATE
DRAWN JEM	8/17/2015
CHECKED RMB	8/17/2015
QA	
MFG	
ENGINEER JEM	8/17/2015
APPROVED RMB	8/17/2015

The PHOENIX Company of Chicago, Inc.

22 GREAT HILL RD., NAUGATUCK, CT 06770
WWW.PHOENIXOFCHICAGO.COM
PHONE: (800) 323-9562 FAX:(630) 206-1801

TITLE
PkZ® PLUG, CRIMP/CLAMP TERMINATION

SIZE	FSCM	DWG NO	REV	PLATING OPT.
B	58167	68-008X-1200	C	A, B, C, D

SCALE 4 : 1 F.S.R. # SHEET 1 OF 1

4

3

2

1