

4

3

2

1

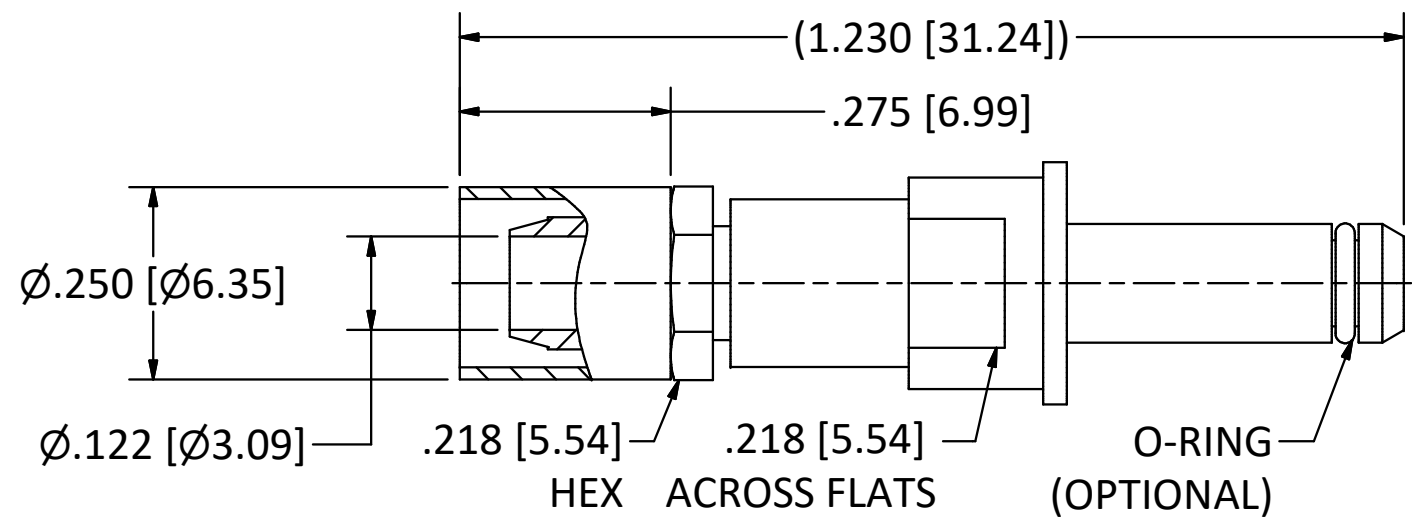
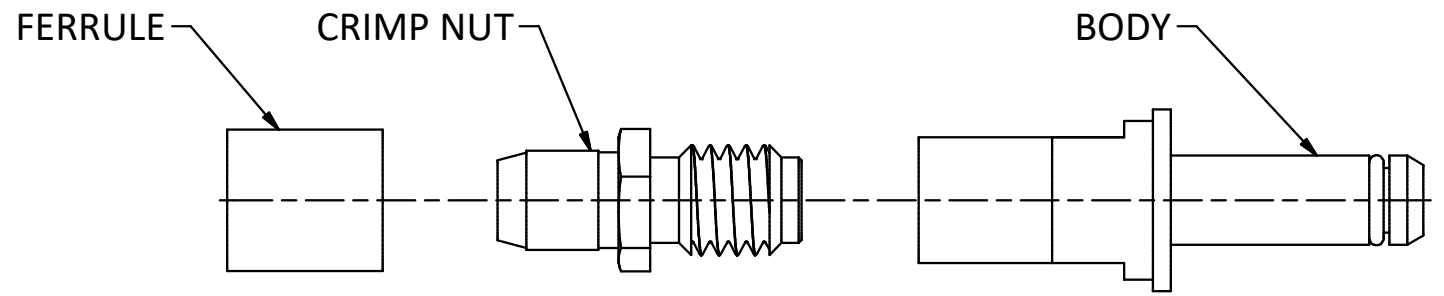

NOTES:

- 1. SPECIFICATIONS PER IDS-68.
- 2. CRIMP NUT AND FERRULE SHIPPED LOOSE.
- 3. ACCOMMODATES RG-55, RG-142, OR RG-223 CABLE.
- 4. CRIMP USING .218 HEX DIE (M22520/5-05).

**HOUSING:** ARINC 600 CONNECTOR PER MIL-C-83527/3, SIZE 8 CAVITY.

PART NUMBER	O-RING OPTIONS
68-0080-1201	NONE
68-0081-1201	ENVIRONMENTAL
68-0082-1201	ENVIRONMENTAL & STABILIZING

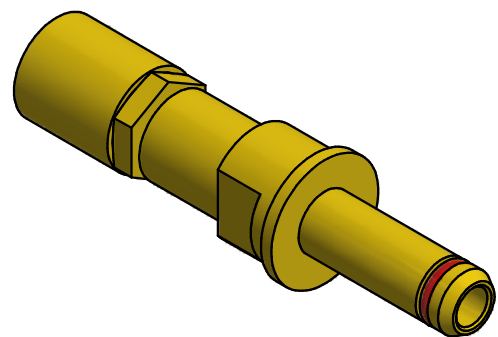

SCALE 2.5 : 1

REV	DESCRIPTION	DATE	BY
H	ECN 13749	4/9/2020	JEM
G	PER ECN 13397	7/11/2919	JEM
F	PER ECN 13062	08/03/18	JEM
E	PER ECN 12964	11/03/17	JEM
D	PER ECN 11074	08/12/11	JEM
C	PER ECN 4037	08/29/97	HN
B	REL ECN 3958	07/08/97	HN

This drawing embodies a proprietary design of The Phoenix Company of Chicago, Inc., Naugatuck, CT 06770. All design, manufacturing, reproduction, use, sale, and other rights regarding the same are expressly reserved. The information in this drawing may be covered completely or in part by patents and/or patents pending.

WARNING - THIS DOCUMENT CONTAINS TECHNICAL DATA WHOSE EXPORT IS RESTRICTED BY THE ARMS EXPORT CONTROL ACT (TITLE 22, U.S.C., SEC 2751, ET. SEQ.) OR THE EXPORT ADMINISTRATION ACT OF 1979, AS AMENDED, TITLE 50, U.S.C., APP 2401 ET SEQ. VIOLATIONS OF THESE EXPORT LAWS ARE SUBJECT TO SEVERE CRIMINAL PENALTIES. DISSEMINATE IN ACCORDANCE WITH PROVISIONS OF DOD DIRECTIVE 5230.25.

Filename: ver2\Autodesk Inventor Data Base\Assemblies\68 Series\68-008X-1201-CU.idw

UNLESS OTHERWISE SPECIFIED, PHOENIX WORKMANSHIP STANDARDS APPLY DIMENSIONS IN INCHES OR (METRIC)

DO NOT SCALE PRINTS  
TOLERANCES ARE:  
FRACTIONS: ± 1/64  
DECIMALS: .XX ± .01  
.XXX ± .003  
ANGLES: ± 1/2°



APPROVALS	DATE
DRAWN JEM	6/27/1997
CHECKED HN	6/2/1997
QA	
MFG	
ENGINEER JEM	6/2/1997
APPROVED HN	6/2/1997

**The PHOENIX Company of Chicago, Inc.**

22 GREAT HILL RD., NAUGATUCK, CT 06770  
WWW.PHOENIXOFCHICAGO.COM  
PHONE: (800) 323-9562 FAX:(630) 206-1801

TITLE  
**PkZ® PLUG, CRIMP/CLAMP TERMINATION**

SIZE <b>B</b>	FSCM 58167	DWG NO <b>68-008X-1201</b>	REV H	PLATING OPT. A, B, C, D
SCALE 4 : 1	F.S.R. #	SHEET 1	OF 1	

4

3

2

1