

1. Trim cable jacket back .480 from the end of the cable. Trim the cable's braided outer conductor to .200 from the cable jacket.

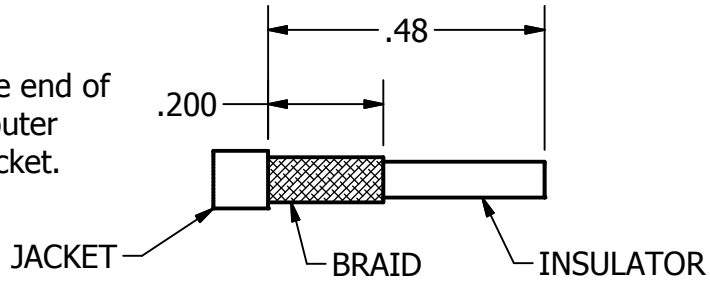

2. Slide the crimp sleeve onto the cable. Orient the back nut with the threads facing away from the cable. Slide the back nut over the cable's dielectric and under the cable braided conductor until it stops on the cable jacket.

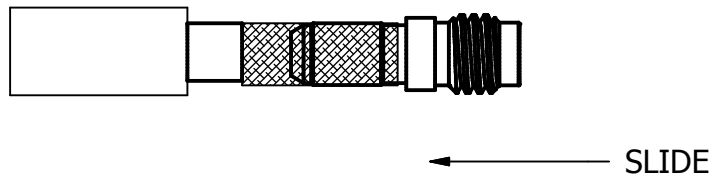

3. Pull the crimp sleeve toward the back nut and over the cable's braided conductor. Crimp the crimp tube using M22520/5-03 and die set A size .128 hex.

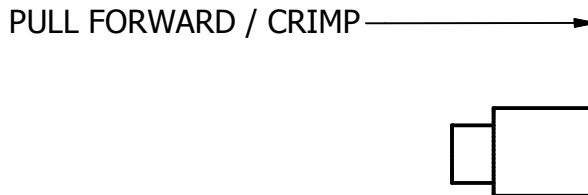

CAD DRAWING - NO MANUAL REVISIONS
 filename: \\PALCODC\BigBoy\Drawings from server2\Autodesk Inventor Data
 Base Assemblies\05 Series\756-0802-0670-CAP.ipt

MATERIAL:				UNLESS OTHERWISE SPECIFIED, PALCO WORKMANSHIP STANDARDS APPLY. DIMENSIONS IN INCHES OR (METRIC) DO NOT SCALE PRINTS TOLERANCES ARE: FRACTIONS: ± 1/64 DECIMALS: .XX ± .01 .XXX ± .005 ANGLES: ± 1/2°		APPROVALS DRAWN: B. KNOTT 11/14/2014 CHECKED: JEM 11/14/2014 QA: MFG: ENGINEER: B. KNOTT 11/14/2014 APPROVED: JEM 11/14/2014		PALCO CONNECTOR 22 GREAT HILL RD., NAUGATUCK, CT 06770 TITLE: Cable Assembly Procedure for 756-0802-0670 SIZE: A FSCM: 58167 DWG NO: 756-0802-0670-CAP REV: C PLATING OPT.	
C	PER ECN 13061	8/3/2018				SCALE		F.S.R. #	
A	REL. PER ECN 12027	12/07/17	JEM			SHEET 1 OF 2			
B	PER ECN 12714	11/14/14	JEM						
REV.	DESCRIPTION	DATE	APPR.						

- 4. Trim the cable dielectric flush to the front of the ferrule. Trim the center conductor to $.08 \pm .01$ extending out from the back nut. Place the spacer onto the cable center conductor. Slide the bullet onto the cable's center conductor and solder it lightly flush to the spacer. Trim any excessive solder from around the contact and contact weep hole.

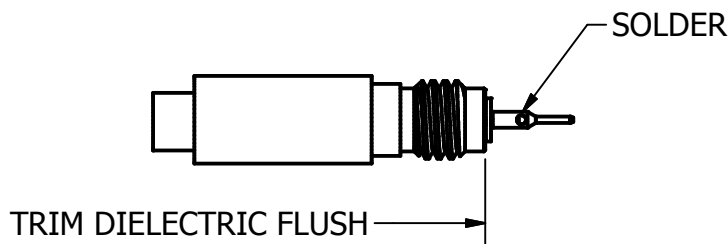

- 5. Slide the body over the contact and onto the back nut. Thread the body onto the back nut. Tighten the body to 4.0 - 6.0 Inch-Lbs. torque using the back nut and body flats.

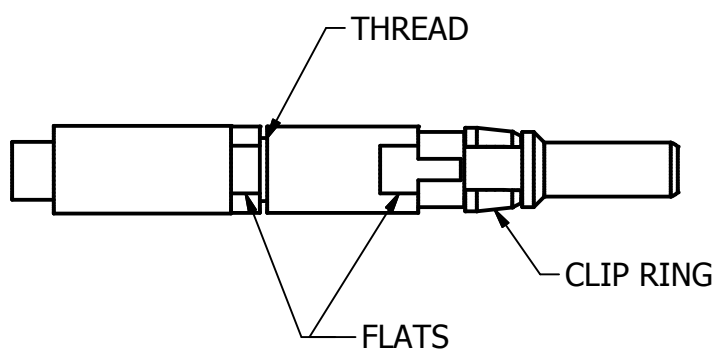

CAD DRAWING - NO MANUAL REVISIONS
 filename: \\PALCODC\BigBoy\Drawings from server2\Autodesk Inventor Data Base Assemblies\756 Series\756-0802-0670-CAP.ipt

MATERIAL:				UNLESS OTHERWISE SPECIFIED, PALCO WORKMANSHIP STANDARDS APPLY. DIMENSIONS IN INCHES OR (METRIC) DO NOT SCALE PRINTS TOLERANCES ARE: FRACTIONS: $\pm 1/64$ DECIMALS: $.XX \pm .01$ $.XXX \pm .005$ ANGLES: $\pm 1/2^\circ$		PALCO CONNECTOR 22 GREAT HILL RD., NAUGATUCK, CT 06770					
THE INFORMATION IN THIS DOCUMENT IS CONFIDENTIAL AND PROPRIETARY AND MAY NOT BE USED FOR ANY PURPOSE WITHOUT THE WRITTEN CONSENT OF PALCO.				APPROVALS DATE DRAWN B. KNOTT 11/14/2014 CHECKED JEM 11/14/2014 QA MFG		TITLE Cable Assembly Procedure for 756-0802-0670					
C	PER ECN 13061	8/3/2018	JEM	ENGINEER	B. KNOTT	11/14/2014	SIZE	FSCM	DWG NO	REV	PLATING OPT.
B	PER ECN 12714	11/14/14	JEM	APPROVED	JEM	11/14/2014	A	58167	756-0802-0670-CAP	C	
A	REL. PER ECN 12027	12/07/17	JEM				SCALE	F.S.R. #	SHEET 2 OF 2		