

4

3

2

1

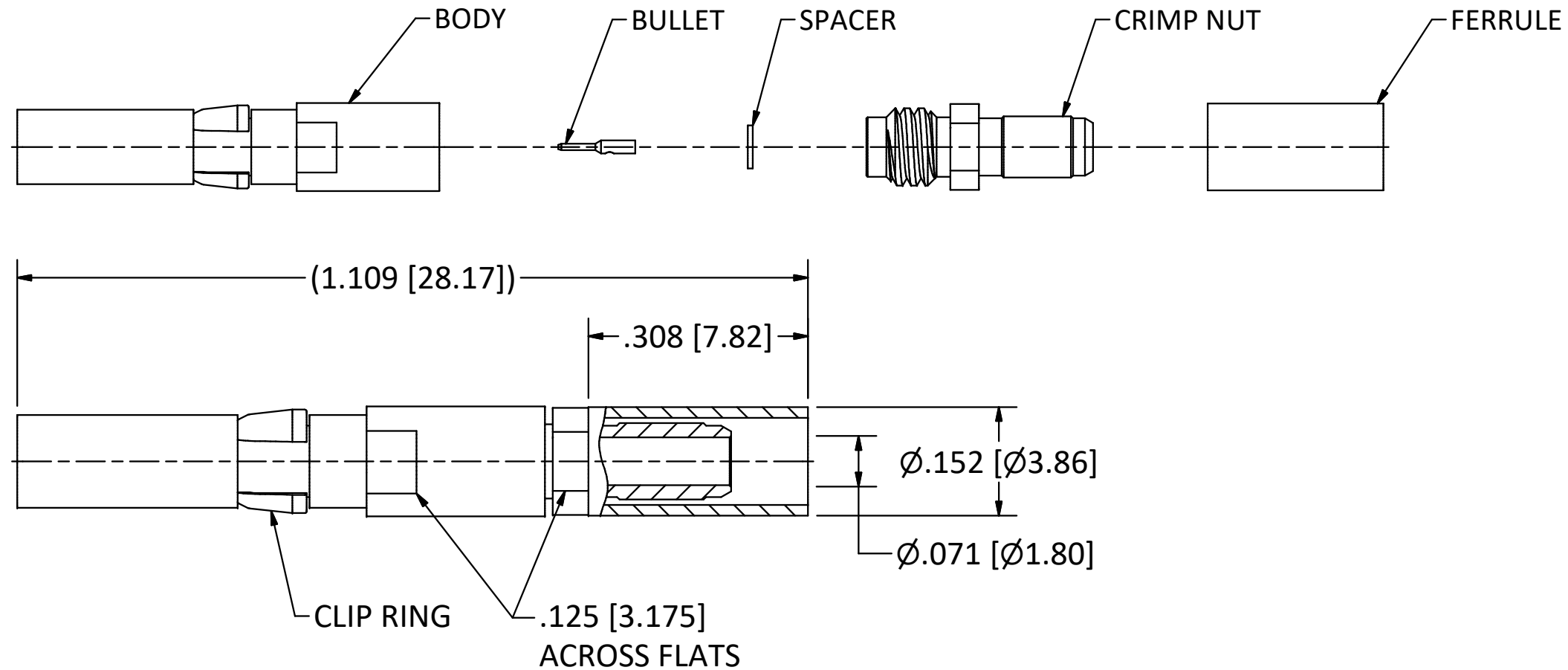

NOTES:

- 1. SPECIFICATIONS PER IDS-756.
  - 2. BULLET, CRIMP NUT, FERRULE, AND SPACER SHIPPED LOOSE.
  - 3. ACCOMMODATES RG-179 CABLE.
  - 4. CRIMP USING .128 HEX DIE (M2252015-03).
- HOUSING:** CUSTOM AND BENDIX LRM, SIZE 12 CAVITY.

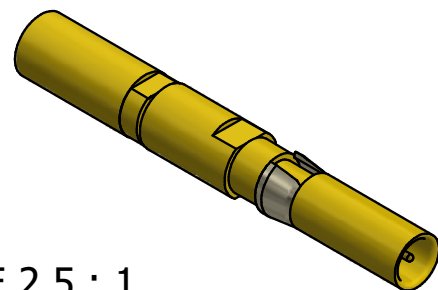

SCALE 2.5 : 1

C	PER ECN 13061	8/3/18	JEM
B	PER ECN 12713	12/7/17	JEM
A	PER ECN 12027	11/14/14	JEM
REV	DESCRIPTION	DATE	BY

This drawing embodies a proprietary design of The Phoenix Company of Chicago, Inc., Naugatuck, CT 06770. All design, manufacturing, reproduction, use, sale, and other rights regarding the same are expressly reserved. The information in this drawing may be covered completely or in part by patents and/or patents pending.

WARNING - THIS DOCUMENT CONTAINS TECHNICAL DATA WHOSE EXPORT IS RESTRICTED BY THE ARMS EXPORT CONTROL ACT (TITLE 22, U.S.C., SEC 2751, ET. SEQ.) OR THE EXPORT ADMINISTRATION ACT OF 1979, AS AMENDED, TITLE 50, U.S.C., APP 2401 ET SEQ. VIOLATIONS OF THESE EXPORT LAWS ARE SUBJECT TO SEVERE CRIMINAL PENALTIES. DISSEMINATE IN ACCORDANCE WITH PROVISIONS OF DOD DIRECTIVE 5230.25.

Filename: \\Autodesk Inventor Data Base\Assemblies\78 Series\78-1080-0670-CU-Layout for C Sized Drawing.idw

UNLESS OTHERWISE SPECIFIED, PHOENIX WORKMANSHIP STANDARDS APPLY DIMENSIONS IN INCHES OR (METRIC)

DO NOT SCALE PRINTS  
TOLERANCES ARE:  
FRACTIONS: ± 1/64  
DECIMALS: .XX ± .01  
.XXX ± .003  
ANGLES: ± 1/2°

$\sqrt[32]{}$

	APPROVALS	DATE
DRAWN	BK	11/14/2014
CHECKED	JEM	11/14/2014
QA		
MFG		
ENGINEER	BK	11/14/2014
APPROVED	JEM	11/14/2014

The **PHOENIX** Company of Chicago, Inc.

22 GREAT HILL RD., NAUGATUCK, CT 06770  
WWW.PHOENIXOFCHICAGO.COM  
PHONE: (800) 323-9562 FAX:(630) 206-1801

TITLE  
**75 OHM, PkZ<sup>®</sup> RECEPTACLE,  
CRIMP/CLAMP TERMINATION**

SIZE	FSCM	DWG NO	REV	PLATING OPT.
<b>B</b>	58167	<b>756-1802-0670</b>	C	A, B, C, D
SCALE	5: 1	F.S.R. #	SHEET	1 OF 1

4

3

2

1