

NOTES:

1. SPECIFICATIONS PER IDS-76.
 2. FERRULE, CRIMP NUT, SPACER, BULLET, AND BULLET SUPPORT SHIPPED LOOSE.
 3. ACCOMMODATES RG-179 CABLE.
 4. CRIMP USING .128 HEX DIE (M22520/5-03).
- HOUSING:** D-SUBMINIATURE, SIZE 8 CAVITY.

PART NUMBER	O-RING OPTIONS
26-0080-0670	NONE
26-0081-0670	ENVIRONMENTAL
26-0083-0670	EMI SPRING
26-0085-0670	GROUNDING RING

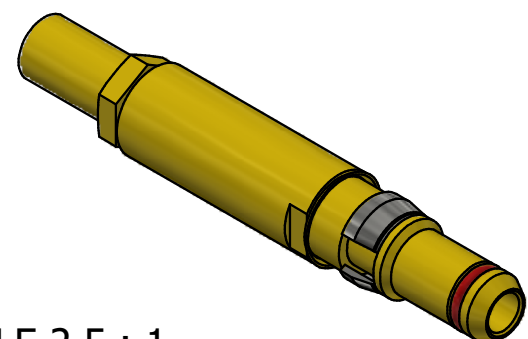

SCALE 2.5 : 1

REV.	DESCRIPTION	DATE	BY
D	PER ECN 13933	12/22/2020	JEM
C	ECN 13058	8/2/18	JEM
B	ECN 11908	6/32/14	JEM
A	ECN 11738	7/23/13	JEM
02	CHANGE OD	4/7/11	JEM
01	PRELIMINARY	4/1/11	JEM

This drawing embodies a proprietary design of The Phoenix Company of Chicago, Inc., Naugatuck, CT 06770. All design, manufacturing, reproduction, use, sale, and other rights regarding the same are expressly reserved. The information in this drawing may be covered completely or in part by patents and/or patents pending.

WARNING - THIS DOCUMENT CONTAINS TECHNICAL DATA WHOSE EXPORT IS RESTRICTED BY THE ARMS EXPORT CONTROL ACT (TITLE 22, U.S.C., SEC 2751, ET. SEQ.) OR THE EXPORT ADMINISTRATION ACT OF 1979, AS AMENDED, TITLE 50, U.S.C., APP 2401 ET SEQ. VIOLATIONS OF THESE EXPORT LAWS ARE SUBJECT TO SEVERE CRIMINAL PENALTIES. DISSEMINATE IN ACCORDANCE WITH PROVISIONS OF DOD DIRECTIVE 5230.25.

Filename: ver2\Autodesk Inventor Data Base\Assemblies\76 Series\76-008X-0670-CU.idw

UNLESS OTHERWISE SPECIFIED, PHOENIX WORKMANSHIP STANDARDS APPLY DIMENSIONS IN INCHES OR (METRIC)

DO NOT SCALE PRINTS
TOLERANCES ARE:
FRACTIONS: ± 1/64
DECIMALS: .XX ± .01
.XXX ± .003
ANGLES: ± 1/2°



APPROVALS	DATE
DRAWN MS	4/1/2011
CHECKED JEM	4/1/2011
QA	
MFG	
ENGINEER MS	4/1/2011
APPROVED JEM	4/1/2011

The PHOENIX Company of Chicago, Inc.

22 GREAT HILL RD., NAUGATUCK, CT 06770
WWW.PHOENIXOFCHICAGO.COM
PHONE: (800) 323-9562 FAX:(630) 206-1801

TITLE
75 OHM, PkZ® PLUG, CRIMP/CLAMP TERMINATION

SIZE	FSCM	DWG NO	REV	PLATING OPT.
B	58167	76-008X-0670	D	A, B, C, D
SCALE	4 : 1	F.S.R. #	SHEET	1 OF 1