

4 | 3 | 2 | 1

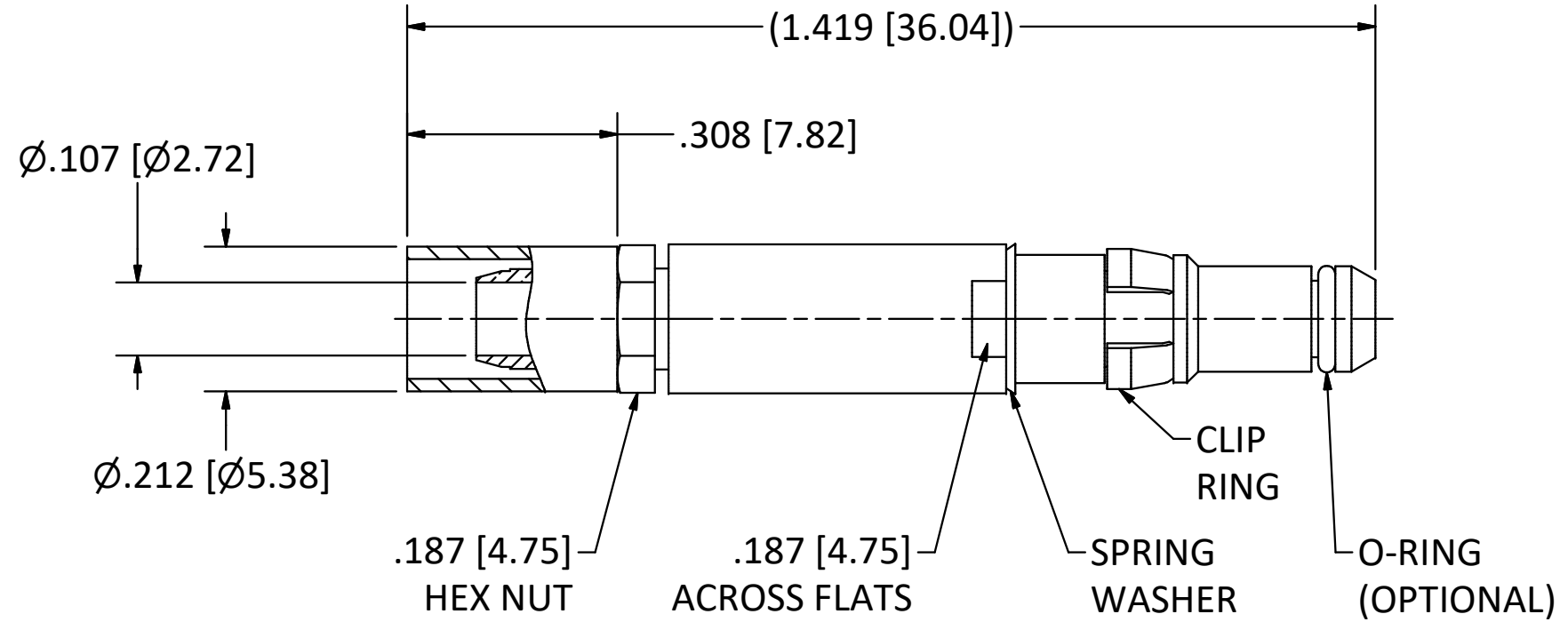

- NOTES:
- SPECIFICATIONS PER IDS-76.
  - FERRULE, SPACER, AND CRIMP NUT SHIPPED LOOSE.
  - ACCOMMODATES BELDEN 1855 CABLE.
  - CRIMP USING .178 HEX DIE (M22520/5-05).
- HOUSING:** D-SUBMINIATURE, SIZE 8 CAVITY.

PART NUMBER	O-RING OPTIONS
76-0080-1082	NONE
76-0081-1082	ENVIRONMENTAL
76-0083-1082	EMI SPRING
76-0085-1082	GROUNDING RING

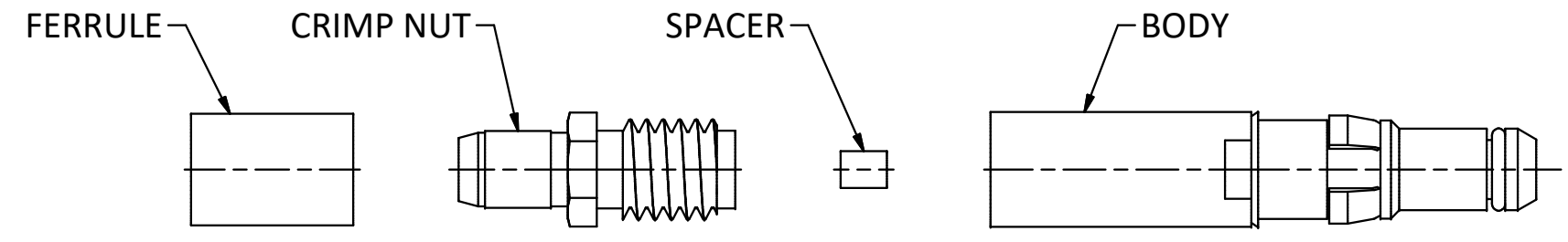
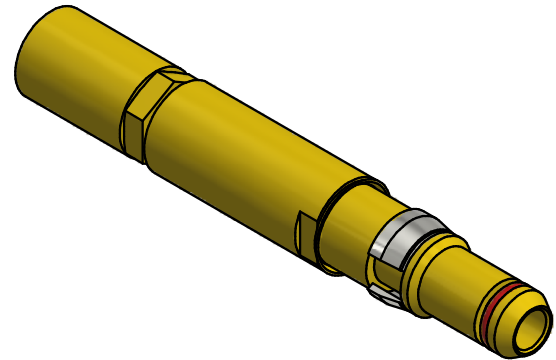

SCALE 2.5 : 1

REV.	DESCRIPTION	DATE	BY
D	ECN 13165	10/25/18	JEM
C	ECN 13058	8/2/18	JEM
B	ECN 11825	12/18/13	JEM
A	ECN 11704	7/18/13	JEM

This drawing embodies a proprietary design of The Phoenix Company of Chicago, Inc., Naugatuck, CT 06770. All design, manufacturing, reproduction, use, sale, and other rights regarding the same are expressly reserved. The information in this drawing may be covered completely or in part by patents and/or patents pending.

WARNING - THIS DOCUMENT CONTAINS TECHNICAL DATA WHOSE EXPORT IS RESTRICTED BY THE ARMS EXPORT CONTROL ACT (TITLE 22, U.S.C., SEC 2751, ET. SEQ.) OR THE EXPORT ADMINISTRATION ACT OF 1979, AS AMENDED, TITLE 50, U.S.C., APP 2401 ET SEQ. VIOLATIONS OF THESE EXPORT LAWS ARE SUBJECT TO SEVERE CRIMINAL PENALTIES. DISSEMINATE IN ACCORDANCE WITH PROVISIONS OF DOD DIRECTIVE 5230.25.

Filename: ver2\Autodesk Inventor Data Base\Assemblies\76 Series\76-008X-1082-CU.idw		
UNLESS OTHERWISE SPECIFIED, PHOENIX WORKMANSHIP STANDARDS APPLY DIMENSIONS IN INCHES OR (METRIC)  DO NOT SCALE PRINTS  TOLERANCES ARE: FRACTIONS: ± 1/64 DECIMALS: .XX ± .01 .XXX ± .003 ANGLES: ± 1/2°	APPROVALS	DATE
	DRAWN JEM	7/18/2013
	CHECKED JEM	7/18/2013
	QA	
	MFG	
	ENGINEER JEM	7/18/2013
APPROVED JEM	7/18/2013	

**The PHOENIX Company of Chicago, Inc.**  
 22 GREAT HILL RD., NAUGATUCK, CT 06770  
 WWW.PHOENIXOFCHICAGO.COM  
 PHONE: (800) 323-9562 FAX:(630) 206-1801

TITLE  
**PkZ® PLUG, CRIMP/CLAMP TERMINATION**

SIZE <b>B</b>	FSCM 58167	DWG NO <b>76-008X-1082</b>	REV D	PLATING OPT. A, B, C, D
SCALE 2.5 : 1		F.S.R. #	SHEET 1 OF 1	

4 | 3 | 2 | 1