

4

3

2

1

B

B

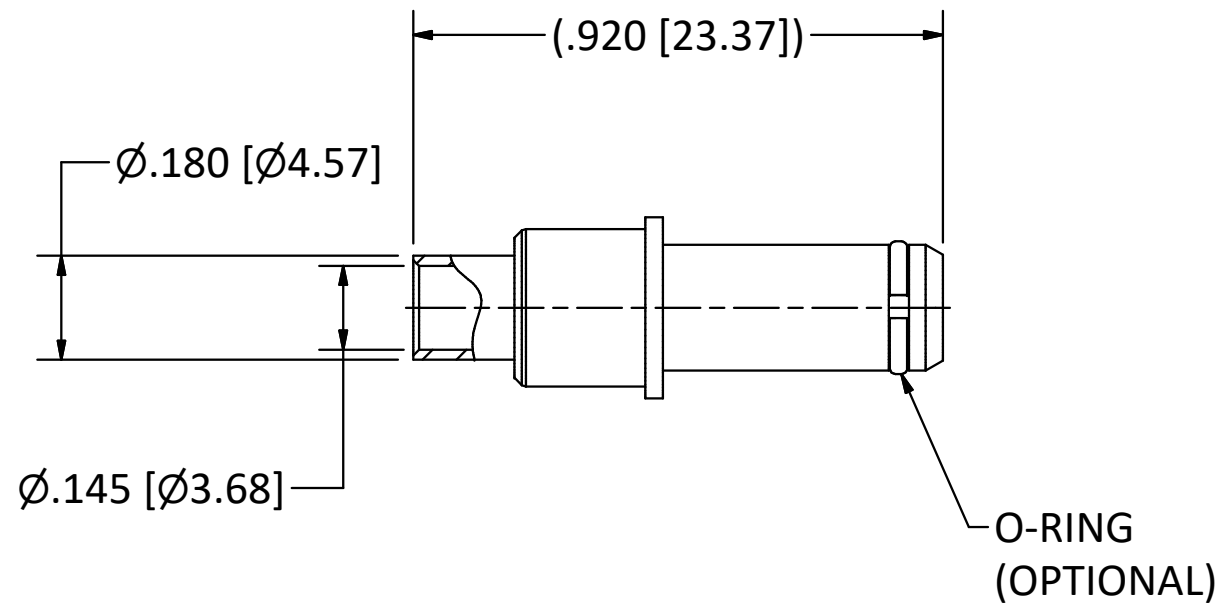

NOTES:

- 1. SPECIFICATIONS PER IDS-78.
 - 2. ACCOMMODATES RG-402 (.141 SEMI-RIGID) OR EQUIVALENT FLEXIBLE CABLE.
- HOUSING:** MIL-C-38999 SERIES I-IV AND MIGHTY MOUSE SERIES 80, SIZE 8 CAVITY.

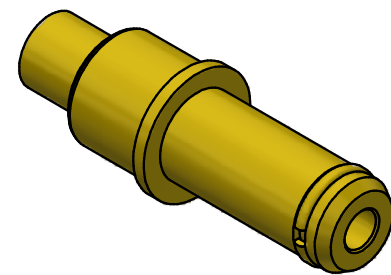

SCALE 2.5 : 1

D	PER ECN 12953	5/23/18	JEM
C	PER ECN 8560	6/20/06	JEM
B	PER ECN 8449	4/7/06	JEM
A	PER ECN 5496	6/7/00	HN
REV	DESCRIPTION	DATE	BY

This drawing embodies a proprietary design of The Phoenix Company of Chicago, Inc., Naugatuck, CT 06770. All design, manufacturing, reproduction, use, sale, and other rights regarding the same are expressly reserved. The information in this drawing may be covered completely or in part by patents and/or patents pending.

WARNING - THIS DOCUMENT CONTAINS TECHNICAL DATA WHOSE EXPORT IS RESTRICTED BY THE ARMS EXPORT CONTROL ACT (TITLE 22, U.S.C., SEC 2751, ET. SEQ.) OR THE EXPORT ADMINISTRATION ACT OF 1979, AS AMENDED, TITLE 50, U.S.C., APP 2401 ET SEQ. VIOLATIONS OF THESE EXPORT LAWS ARE SUBJECT TO SEVERE CRIMINAL PENALTIES. DISSEMINATE IN ACCORDANCE WITH PROVISIONS OF DOD DIRECTIVE 5230.25.

Filename: ver2\Autodesk Inventor Data Base\Assemblies\78 Series\78-002X-1410-CU.idw

UNLESS OTHERWISE SPECIFIED, PHOENIX WORKMANSHIP STANDARDS APPLY DIMENSIONS IN INCHES OR (METRIC)

DO NOT SCALE PRINTS
TOLERANCES ARE:
FRACTIONS: $\pm 1/64$
DECIMALS: $.XX \pm .01$
 $.XXX \pm .003$
ANGLES: $\pm 1/2^\circ$



APPROVALS	DATE
DRAWN YT	6/7/2000
CHECKED HN	6/7/2000
QA	
MFG	
ENGINEER YT	6/7/2000
APPROVED HN	6/7/2000

PART NUMBER	O-RING OPTIONS
78-0020-1410	NONE
78-0025-1410	GROUNDING RING

The PHOENIX Company of Chicago, Inc.

22 GREAT HILL RD., NAUGATUCK, CT 06770
WWW.PHOENIXOFCHICAGO.COM
PHONE: (800) 323-9562 FAX:(630) 206-1801

TITLE
PkZ® PLUG, DIRECT SOLDER TERMINATION

SIZE B	FSCM 58167	DWG NO 78-002X-1410	REV D	PLATING OPT. A, B, C, D
SCALE 3 : 1	F.S.R. #	SHEET 1	OF 1	

4

3

2

1

A

A