

4

3

2

1

B

B

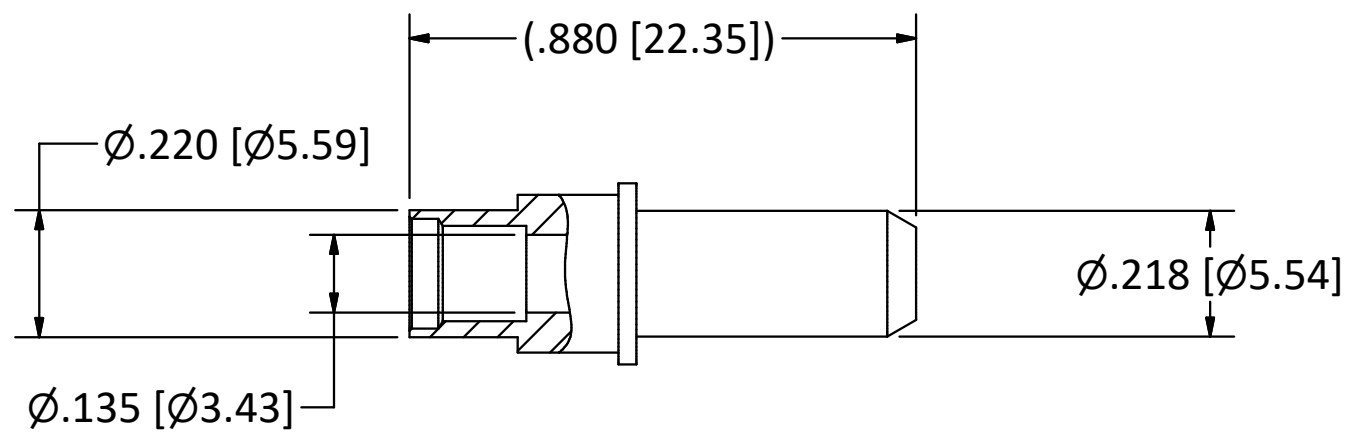

- NOTES:  
 1. SPECIFICATIONS PER IDS-78.  
 2. ACCOMMODATES TIMES MICROWAVES SFT-142 OR EQUIVALENT CABLE.  
 3. EXTRACTION TOOL M81969/8-14 REQUIRED TO REMOVE CONTACTS.  
**HOUSING:** MIL-C-38999 SERIES I-IV AND MIGHTY MOUSE SERIES 80, SIZE 8 CAVITY.

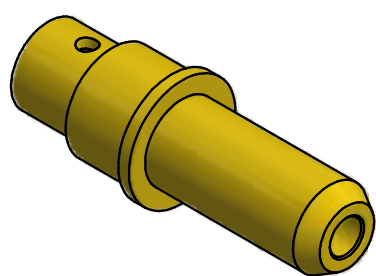

SCALE 2.5 : 1

4

3

2

1

A

A

				<p>This drawing embodies a proprietary design of The Phoenix Company of Chicago, Inc., Naugatuck, CT 06770. All design, manufacturing, reproduction, use, sale, and other rights regarding the same are expressly reserved. The information in this drawing may be covered completely or in part by patents and/or patents pending.</p>	<p>WARNING - THIS DOCUMENT CONTAINS TECHNICAL DATA WHOSE EXPORT IS RESTRICTED BY THE ARMS EXPORT CONTROL ACT (TITLE 22, U.S.C., SEC 2751, ET. SEQ.) OR THE EXPORT ADMINISTRATION ACT OF 1979, AS AMENDED, TITLE 50, U.S.C., APP 2401 ET SEQ. VIOLATIONS OF THESE EXPORT LAWS ARE SUBJECT TO SEVERE CRIMINAL PENALTIES. DISSEMINATE IN ACCORDANCE WITH PROVISIONS OF DOD DIRECTIVE 5230.25.</p>	Filename: ver2\Autodesk Inventor Data Base\Assemblies\78 Series\78-0020-2202-CU.idw		<b>The PHOENIX Company of Chicago, Inc.</b> 22 GREAT HILL RD., NAUGATUCK, CT 06770 WWW.PHOENIXOFCHICAGO.COM PHONE: (800) 323-9562 FAX:(630) 206-1801			
						UNLESS OTHERWISE SPECIFIED, PHOENIX WORKMANSHIP STANDARDS APPLY DIMENSIONS IN INCHES OR (METRIC)	APPROVALS	DATE	TITLE <b>PKZ® PLUG, DIRECT SOLDER TERMINATION</b>		
						DO NOT SCALE PRINTS	DRAWN				
						TOLERANCES ARE: FRACTIONS: $\pm 1/64$ DECIMALS: $.XX \pm .01$ $.XXX \pm .003$ ANGLES: $\pm 1/2^\circ$	CHECKED				
							QA				
					MFG						
D	PER ECN 13449	8/12/2019	JEM		ENGINEER	8/3/2010	SIZE	FSCM	DWG NO	REV	PLATING OPT.
C	PER ECN 12979	06/06/18	JEM		MS		B	58167	<b>78-0020-2202</b>	D	A, B, C, D
B	PER ECN 12953	05/23/18	JEM		JEM	8/3/2010	SCALE	3 : 1	F.S.R. #	SHEET	1 OF 1
A	PER ECN 12353	8/24/19	JEM		APPROVED						
D	PRELIMINARY	08/03/10	JEM		JEM	8/3/2010					
REV	DESCRIPTION	DATE	BY								