

CABLE ASSEMBLY PROCEDURE	
P/N	78-002X-1410
PAGE 1 OF 2	DATE: 06/07/00
DRAWN: EK	APPROVED: JEM
FOR USE WITH RG-402 CABLE	

PALEO
CONNECTOR

22 GREAT HILL ROAD, NAUGATUCK, CT. 06770
PHONE: (203) 729-9090 FAX: (203) 723-1794

REV	DESCRIPTION	DATE	APPR
A	REL. ECN 5496	06/07/00	HN
B	PER ECN 8449	04/07/06	JEM
C	PER ECN 8560	06/20/06	JEM
D	PER ECN 12953	05/23/18	JEM

FOR USE WITH RG-402 CABLE

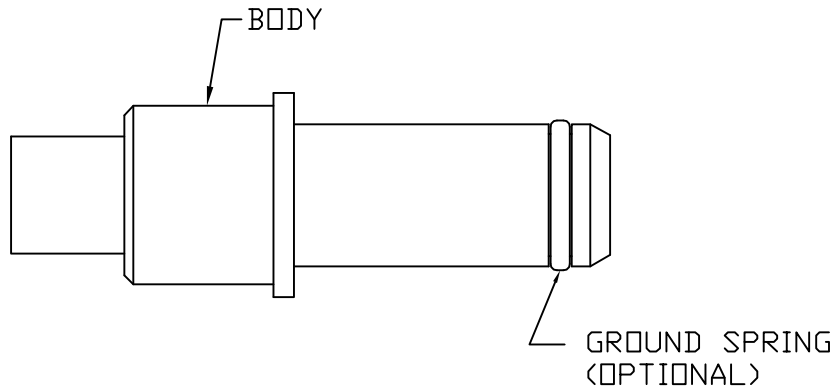

STEP 1
TRIM CABLE TO DIMENSIONS SHOWN. POINT CENTER CONDUCTOR.

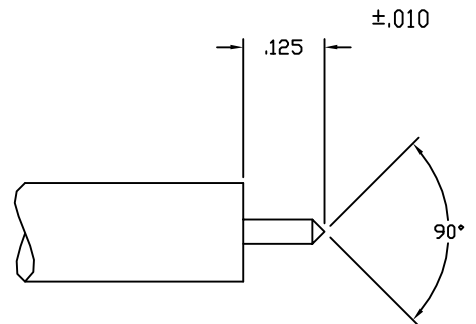

STEP 2
INSERT CABLE INTO BACK OF BODY AND SOLDER TUBE TO CONNECTOR AS SHOWN. CLEAN SOLDER JOINT.

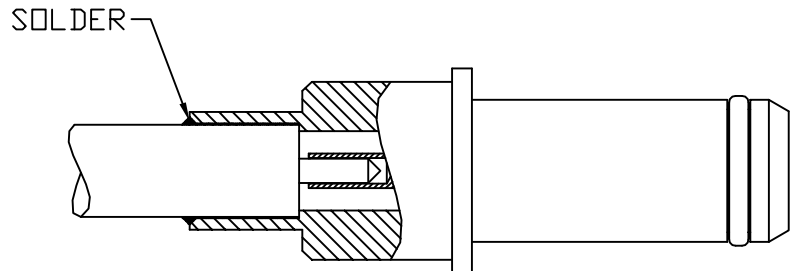

CABLE ASSEMBLY PROCEDURE	
P/N	78-002X-1410
PAGE 2 OF 2	DATE: 06/07/00
DRAWN: EK	APPROVED: JEM
FOR USE WITH TFLEX 402 CABLE	

PALEO
CONNECTOR

22 GREAT HILL ROAD, NAUGATUCK, CT. 06770
PHONE: (203) 729-9090 FAX: (203) 723-1794

REV	DESCRIPTION	DATE	APPR
A	PER ECN 5496	06/07/00	HN
B	PER ECN 8449	04/10/06	JEM
C	PER ECN 8560	06/20/06	JEM
D	PER ECN 12953	05/23/18	JEM

FOR USE WITH TFLEX-402 CABLE

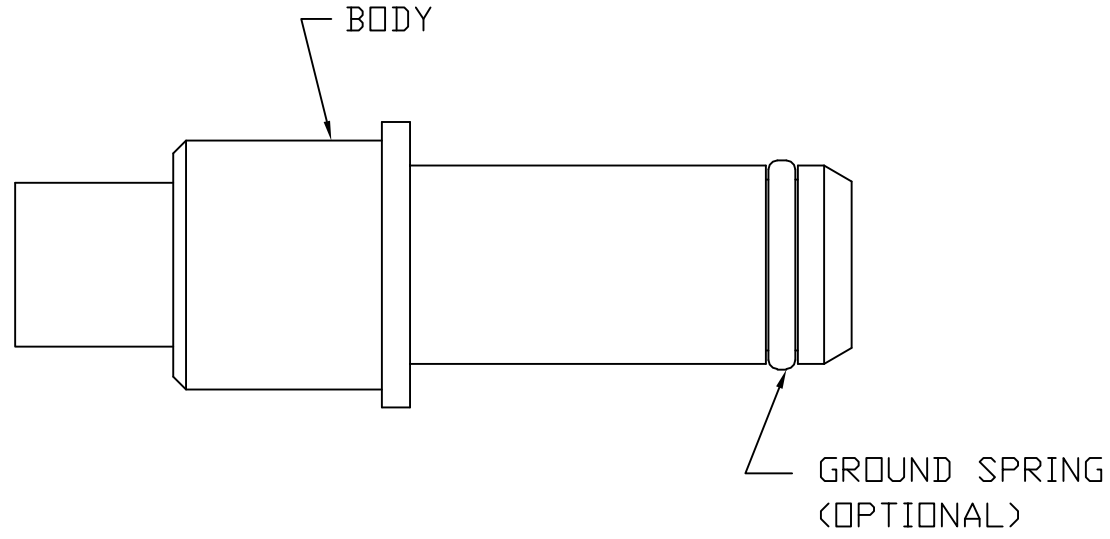

STEP 1
TRIM CABLE TO DIMENSION SHOWN.
POINT CENTER CONDUCTOR.

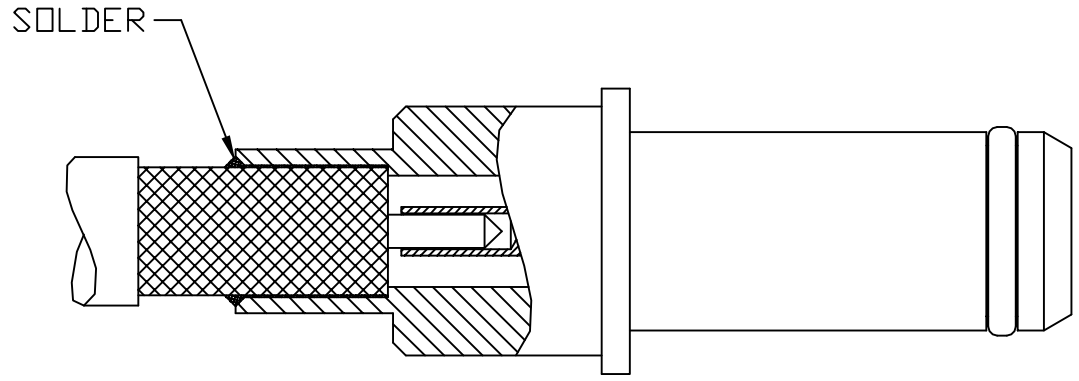
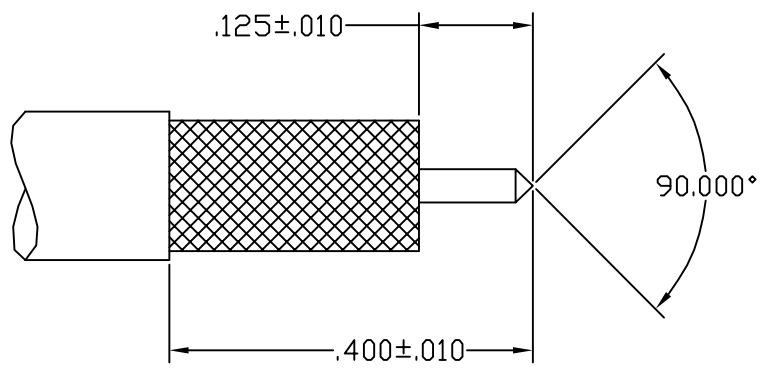

STEP 2
INSERT CABLE INTO BODY UNTIL
OUTER CONDUCTOR FLUSH WITH
BODY SHOULDER. SOLDER OUTER
CONDUCTOR IN BODY. CLEAN.