

4

3

2

1

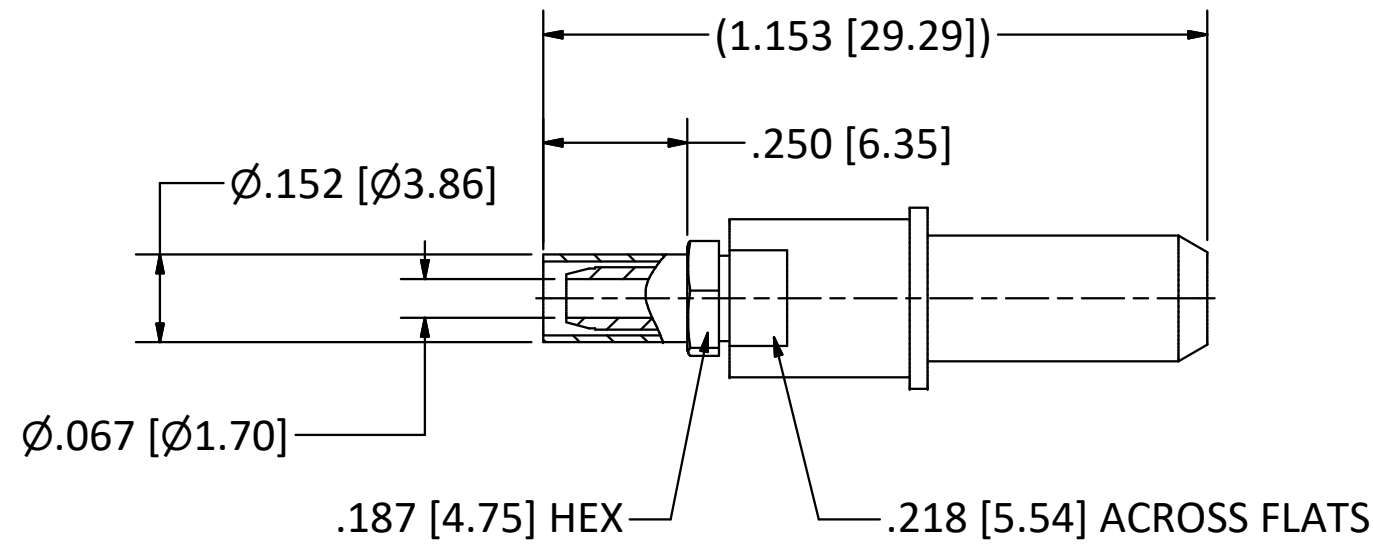
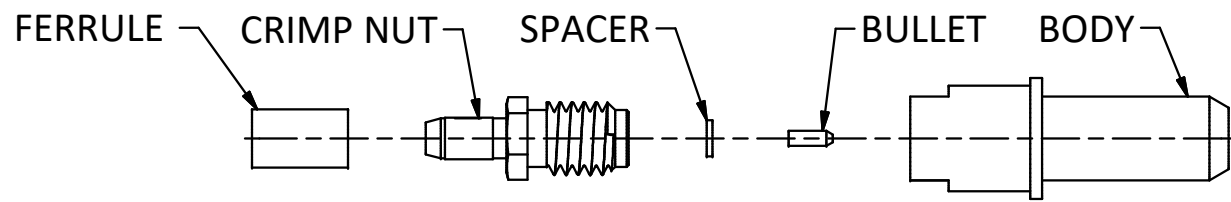

- NOTES:
1. SPECIFICATIONS PER IDS-78.
 2. BULLET, FERRULE, CRIMP NUT & SPACER SHIPPED LOOSE.
 3. ACCOMMODATES RG-174, RG-179, RG-187, RG-188, OR RG-316 CABLE.
 4. CRIMP USING .128 HEX DIE (M22520-5/03).
- HOUSING:** MIL-C-38999 SERIES I-IV AND MIGHTY MOUSE SERIES 80, SIZE 8 CAVITY.

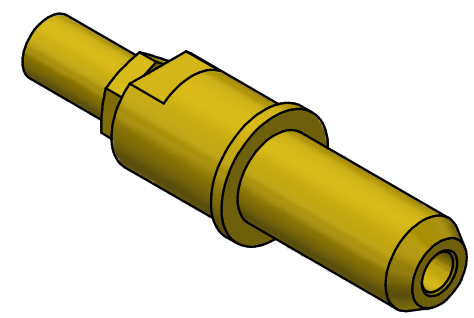

SCALE 2.5 : 1

G	PER ECN 13454	8/14/2019	JEM
F	PER ECN 12955	5/23/18	JEM
REV	DESCRIPTION	DATE	BY

This drawing embodies a proprietary design of The Phoenix Company of Chicago, Inc., Naugatuck, CT 06770. All design, manufacturing, reproduction, use, sale, and other rights regarding the same are expressly reserved. The information in this drawing may be covered completely or in part by patents and/or patents pending.

WARNING - THIS DOCUMENT CONTAINS TECHNICAL DATA WHOSE EXPORT IS RESTRICTED BY THE ARMS EXPORT CONTROL ACT (TITLE 22, U.S.C., SEC 2751, ET. SEQ.) OR THE EXPORT ADMINISTRATION ACT OF 1979, AS AMENDED, TITLE 50, U.S.C., APP 2401 ET SEQ. VIOLATIONS OF THESE EXPORT LAWS ARE SUBJECT TO SEVERE CRIMINAL PENALTIES. DISSEMINATE IN ACCORDANCE WITH PROVISIONS OF DOD DIRECTIVE 5230.25.

Filename: ver2\Autodesk Inventor Data Base\Assemblies\78 Series\78-0080-0670-CU.idw		
UNLESS OTHERWISE SPECIFIED, PHOENIX WORKMANSHIP STANDARDS APPLY DIMENSIONS IN INCHES OR (METRIC) DO NOT SCALE PRINTS TOLERANCES ARE: FRACTIONS: ± 1/64 DECIMALS: .XX ± .01 .XXX ± .003 ANGLES: ± 1/2°	APPROVALS	DATE
	DRAWN JEM	8/17/1998
	CHECKED HN	8/17/1998
	QA	
	MFG	
ENGINEER JEM	8/17/1998	
APPROVED HN	8/17/1998	

The PHOENIX Company of Chicago, Inc.			
22 GREAT HILL RD., NAUGATUCK, CT 06770 WWW.PHOENIXOFCHICAGO.COM PHONE: (800) 323-9562 FAX:(630) 206-1801			
TITLE PkZ® PLUG, CRIMP/CLAMP TERMINATION			
SIZE B	FSCM 58167	DWG NO 78-0080-0670	REV G
PLATING OPT. A, B, C, D	SCALE 3 : 1	F.S.R. #	SHEET 1 OF 1

4

3

2

1