

4

3

2

1

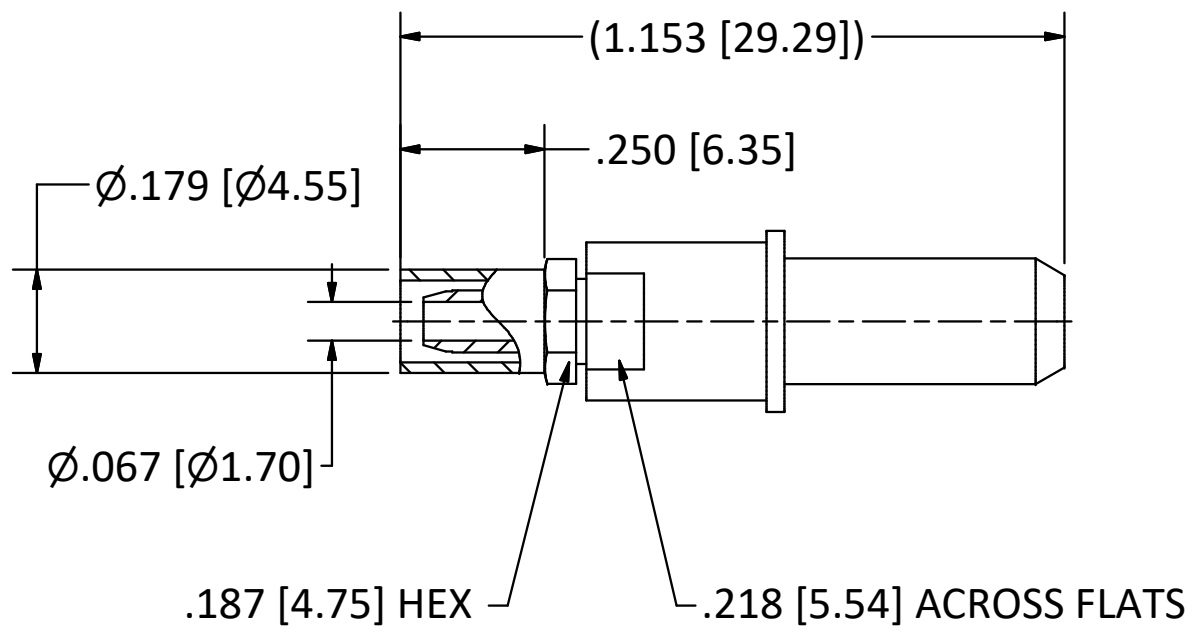
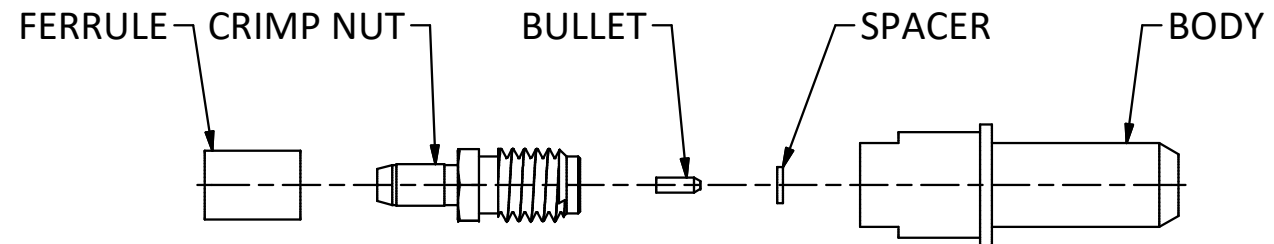

- NOTES:
1. SPECIFICATIONS PER IDS-78.
 2. BULLET, FERRULE, CRIMP NUT, AND SPACER SHIPPED LOOSE.
 3. ACCOMMODATES RG-316 DOUBLE SHIELD (M17/152) CABLE.
 4. CRIMP USING .151 HEX DIE (M22520/5-37).
- HOUSING:** MIL-C-38999 SERIES I-IV AND MIGHTY MOUSE SERIES 80, SIZE 8 CAVITY.

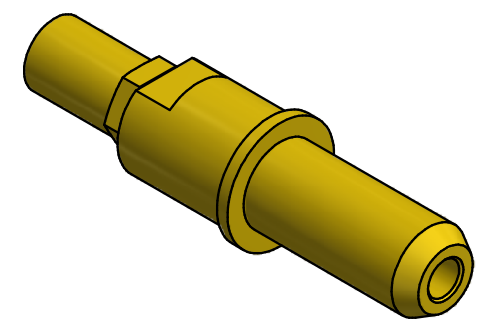

SCALE 2.5 : 1

<p>This drawing embodies a proprietary design of The Phoenix Company of Chicago, Inc., Naugatuck, CT 06770. All design, manufacturing, reproduction, use, sale, and other rights regarding the same are expressly reserved. The information in this drawing may be covered completely or in part by patents and/or patents pending.</p>				<p>WARNING - THIS DOCUMENT CONTAINS TECHNICAL DATA WHOSE EXPORT IS RESTRICTED BY THE ARMS EXPORT CONTROL ACT (TITLE 22, U.S.C., SEC 2751, ET. SEQ.) OR THE EXPORT ADMINISTRATION ACT OF 1979, AS AMENDED, TITLE 50, U.S.C., APP 2401 ET SEQ. VIOLATIONS OF THESE EXPORT LAWS ARE SUBJECT TO SEVERE CRIMINAL PENALTIES. DISSEMINATE IN ACCORDANCE WITH PROVISIONS OF DOD DIRECTIVE 5230.25.</p>				<p>Filename: ver2\Autodesk Inventor Data Base\Assemblies\78 Series\78-0080-2670-CU.idw</p>				<p>The PHOENIX Company of Chicago, Inc. 22 GREAT HILL RD., NAUGATUCK, CT 06770 WWW.PHOENIXOFCHICAGO.COM PHONE: (800) 323-9562 FAX:(630) 206-1801</p>																													
<table border="1"> <tr> <td>G</td> <td>PER ECN 13461</td> <td>08/20/19</td> <td>JEM</td> </tr> <tr> <td>F</td> <td>PER ECN 12955</td> <td>05/13/18</td> <td>JEM</td> </tr> <tr> <td>REV</td> <td>DESCRIPTION</td> <td>DATE</td> <td>BY</td> </tr> </table>				G	PER ECN 13461	08/20/19	JEM	F	PER ECN 12955	05/13/18	JEM	REV	DESCRIPTION	DATE	BY	<p>UNLESS OTHERWISE SPECIFIED, PHOENIX WORKMANSHIP STANDARDS APPLY DIMENSIONS IN INCHES OR (METRIC)</p> <p>DO NOT SCALE PRINTS</p> <p>TOLERANCES ARE: FRACTIONS: ± 1/64 DECIMALS: .XX ± .01 .XXX ± .003 ANGLES: ± 1/2°</p>				<table border="1"> <tr> <th>APPROVALS</th> <th>DATE</th> </tr> <tr> <td>DRAWN YT</td> <td>5/16/2002</td> </tr> <tr> <td>CHECKED HN</td> <td>5/16/2002</td> </tr> <tr> <td>QA</td> <td></td> </tr> <tr> <td>MFG</td> <td></td> </tr> <tr> <td>ENGINEER YT</td> <td>5/16/2002</td> </tr> <tr> <td>APPROVED HN</td> <td>5/16/2002</td> </tr> </table>				APPROVALS	DATE	DRAWN YT	5/16/2002	CHECKED HN	5/16/2002	QA		MFG		ENGINEER YT	5/16/2002	APPROVED HN	5/16/2002	<p>TITLE PkZ® PLUG, CRIMP/CLAMP TERMINATION</p>			
G	PER ECN 13461	08/20/19	JEM																																						
F	PER ECN 12955	05/13/18	JEM																																						
REV	DESCRIPTION	DATE	BY																																						
APPROVALS	DATE																																								
DRAWN YT	5/16/2002																																								
CHECKED HN	5/16/2002																																								
QA																																									
MFG																																									
ENGINEER YT	5/16/2002																																								
APPROVED HN	5/16/2002																																								
				<table border="1"> <tr> <td>SIZE B</td> <td>FSCM 58167</td> <td>DWG NO 78-0080-2670</td> <td>REV F</td> <td>PLATING OPT. A, B, C, D</td> </tr> </table>				SIZE B	FSCM 58167	DWG NO 78-0080-2670	REV F	PLATING OPT. A, B, C, D	<table border="1"> <tr> <td>SCALE 3 : 1</td> <td>F.S.R. #</td> <td>SHEET 1</td> <td>OF 1</td> </tr> </table>				SCALE 3 : 1	F.S.R. #	SHEET 1	OF 1																					
SIZE B	FSCM 58167	DWG NO 78-0080-2670	REV F	PLATING OPT. A, B, C, D																																					
SCALE 3 : 1	F.S.R. #	SHEET 1	OF 1																																						

4

3

2

1