

4

3

2

1

B

B

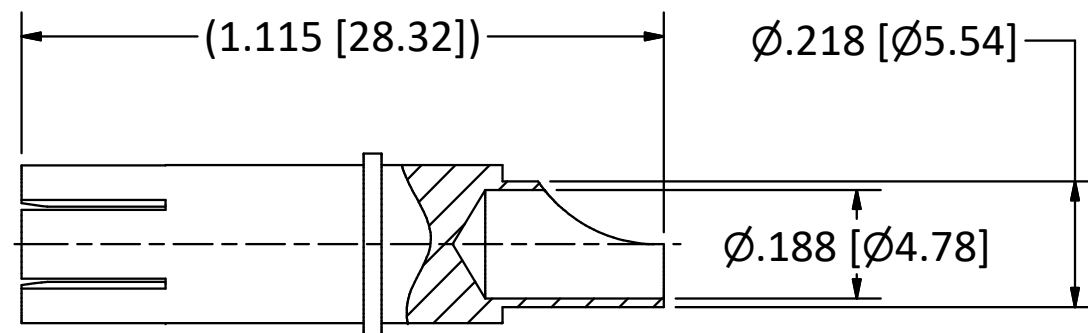

NOTES:

- 1. SPECIFICATIONS PER IDS-78.
- 2. ACCOMMODATES 8 AWG STRANDED WIRE.

**HOUSING:** MIL-C-38999 SERIES I, III, & IV AND MIGHTY MOUSE SERIES 80, SIZE 8 CAVITY.

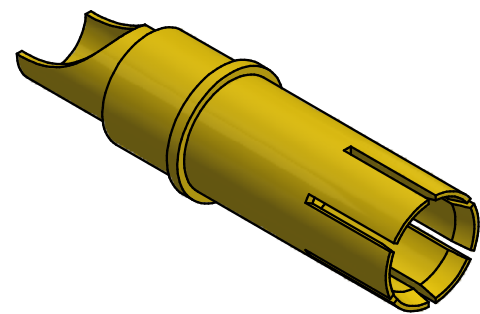

SCALE 2.5 : 1

<p>This drawing embodies a proprietary design of The Phoenix Company of Chicago, Inc., Naugatuck, CT 06770. All design, manufacturing, reproduction, use, sale, and other rights regarding the same are expressly reserved. The information in this drawing may be covered completely or in part by patents and/or patents pending.</p>				<p>WARNING - THIS DOCUMENT CONTAINS TECHNICAL DATA WHOSE EXPORT IS RESTRICTED BY THE ARMS EXPORT CONTROL ACT (TITLE 22, U.S.C., SEC 2751, ET. SEQ.) OR THE EXPORT ADMINISTRATION ACT OF 1979, AS AMENDED, TITLE 50, U.S.C., APP 2401 ET SEQ. VIOLATIONS OF THESE EXPORT LAWS ARE SUBJECT TO SEVERE CRIMINAL PENALTIES. DISSEMINATE IN ACCORDANCE WITH PROVISIONS OF DOD DIRECTIVE 5230.25.</p>		<p>Filename: \\Autodesk Inventor Data Base\Assemblies\78 Series\78-1080-0670-CU-Layout for C Sized Drawing.idw</p>		<p><b>The PHOENIX Company of Chicago, Inc.</b></p> <p>22 GREAT HILL RD., NAUGATUCK, CT 06770 WWW.PHOENIXOFCHICAGO.COM</p> <p>PHONE: (800) 323-9562 FAX:(630) 206-1801</p>											
						<p>UNLESS OTHERWISE SPECIFIED, PHOENIX WORKMANSHIP STANDARDS APPLY DIMENSIONS IN INCHES OR (METRIC)</p> <p>DO NOT SCALE PRINTS</p> <p>TOLERANCES ARE: FRACTIONS: ± 1/64 DECIMALS: .XX ± .01 .XXX ± .003 ANGLES: ± 1/2°</p>		<table border="1"> <thead> <tr> <th>APPROVALS</th> <th>DATE</th> </tr> </thead> <tbody> <tr> <td>DRAWN CA</td> <td>10/21/2019</td> </tr> <tr> <td>CHECKED JEM</td> <td>10/21/2019</td> </tr> <tr> <td>QA</td> <td></td> </tr> <tr> <td>MFG</td> <td></td> </tr> <tr> <td>ENGINEER CA</td> <td>10/21/2019</td> </tr> <tr> <td>APPROVED JEM</td> <td>10/21/2019</td> </tr> </tbody> </table>		APPROVALS	DATE	DRAWN CA	10/21/2019	CHECKED JEM	10/21/2019	QA		MFG	
APPROVALS	DATE																		
DRAWN CA	10/21/2019																		
CHECKED JEM	10/21/2019																		
QA																			
MFG																			
ENGINEER CA	10/21/2019																		
APPROVED JEM	10/21/2019																		
<table border="1"> <thead> <tr> <th>REV</th> <th>DESCRIPTION</th> <th>DATE</th> <th>BY</th> </tr> </thead> <tbody> <tr> <td>B</td> <td>PER ECN 13542</td> <td>10/21/19</td> <td>JEM</td> </tr> <tr> <td>A</td> <td>PER ECN 4527</td> <td>6/28/98</td> <td>HN</td> </tr> </tbody> </table>		REV	DESCRIPTION	DATE	BY	B	PER ECN 13542	10/21/19	JEM	A	PER ECN 4527	6/28/98	HN	<p>SIZE <b>B</b> FSCM 58167 DWG NO <b>78-1020-0001</b> REV B PLATING OPT. A, B, C, D</p>		<p>SCALE 3 : 1 F.S.R. # SHEET 1 OF 1</p>			
REV	DESCRIPTION	DATE	BY																
B	PER ECN 13542	10/21/19	JEM																
A	PER ECN 4527	6/28/98	HN																

4

3

2

1

A

A