

CABLE ASSEMBLY PROCEDURE	
P/N	78-1020-1410
PAGE 1 OF 1	DATE: 11/03/09
DRAWN: MS	APPROVED: JEM
FOR USE WITH RG-405 (M17/130) CABLE	

PALEO
CONNECTOR

22 GREAT HILL ROAD, NAUGATUCK, CT. 06770
PHONE: (203) 729-9090 FAX: (203) 723-1794

REV	DESCRIPTION	DATE	APPR
A	PER ECN 10074	11/03/09	JEM
B	PER ECN 12956	05/24/18	JEM
C	PER ECN 13468	8/22/19	JEM

FOR USE WITH RG-402 CABLE

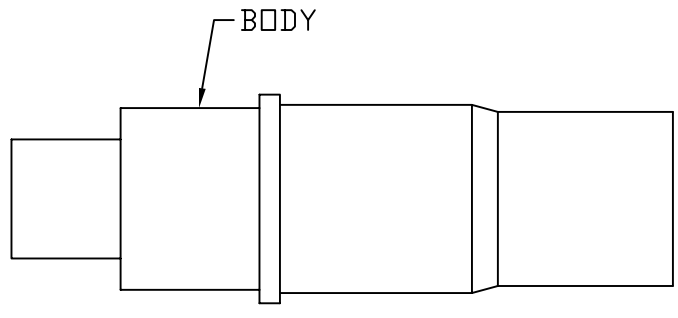

STEP 1
TRIM CABLE TO DIMENSION SHOWN. POINT CENTER CONDUCTOR.

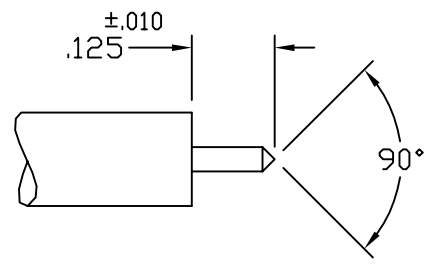

STEP 2
INSERT CABLE INTO BACK OF BODY AND SOLDER TUBE TO CONNECTOR AS SHOWN. CLEAN SOLDER JOINT.

