

4

3

2

1

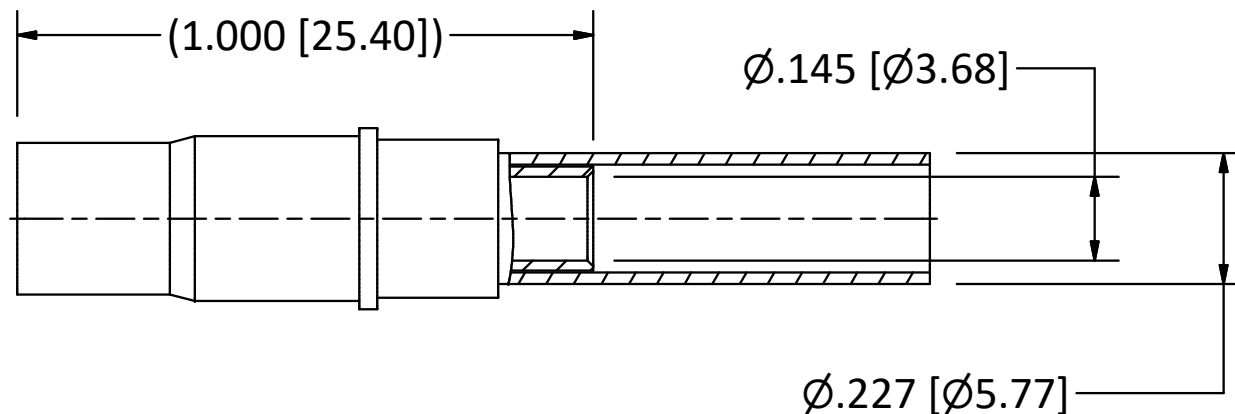
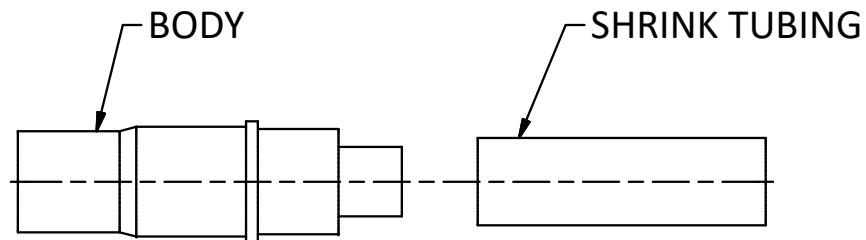

NOTES:

- 1. SPECIFICATIONS PER IDS-78.
- 2. SHRINK TUBING SHIPPED LOOSE.
- 3. ACCOMMODATES HARBOUR SS-402 CABLE.

HOUSING: MIL-C-38999 SERIES I, III, & IV AND MIGHTY MOUSE SERIES 80, SIZE 8 CAVITY.

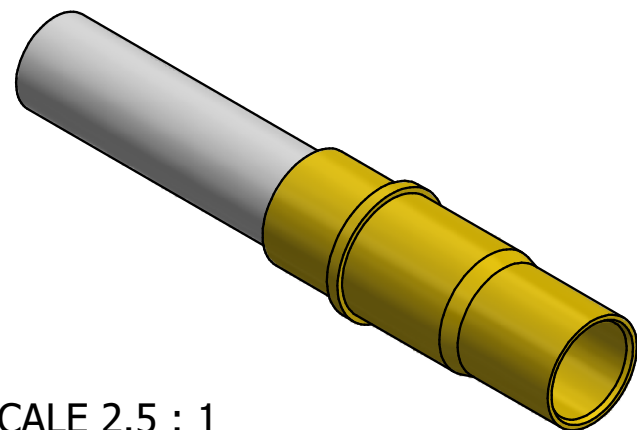

SCALE 2.5 : 1

| | | | |
|-----|---------------|-----------|-----|
| D | PER ECN 13522 | 10/7/2019 | JEM |
| C | PER ECN 9686 | 19/09/08 | JEM |
| B | PER ECN 5534 | 7/18/00 | HN |
| A | REL ECN 4696 | 9/17/98 | HN |
| REV | DESCRIPTION | DATE | BY |

This drawing embodies a proprietary design of The Phoenix Company of Chicago, Inc., Naugatuck, CT 06770. All design, manufacturing, reproduction, use, sale, and other rights regarding the same are expressly reserved. The information in this drawing may be covered completely or in part by patents and/or patents pending.

WARNING - THIS DOCUMENT CONTAINS TECHNICAL DATA WHOSE EXPORT IS RESTRICTED BY THE ARMS EXPORT CONTROL ACT (TITLE 22, U.S.C., SEC 2751, ET. SEQ.) OR THE EXPORT ADMINISTRATION ACT OF 1979, AS AMENDED, TITLE 50, U.S.C., APP 2401 ET SEQ. VIOLATIONS OF THESE EXPORT LAWS ARE SUBJECT TO SEVERE CRIMINAL PENALTIES. DISSEMINATE IN ACCORDANCE WITH PROVISIONS OF DOD DIRECTIVE 5230.25.

Filename: \\Autodesk Inventor Data Base\Assemblies\78 Series\78-1080-0670-CU-Layout for C Sized Drawing.idw

UNLESS OTHERWISE SPECIFIED, PHOENIX WORKMANSHIP STANDARDS APPLY DIMENSIONS IN INCHES OR (METRIC)

DO NOT SCALE PRINTS
TOLERANCES ARE:
FRACTIONS: ± 1/64
DECIMALS: .XX ± .01
.XXX ± .003
ANGLES: ± 1/2°

32√

| APPROVALS | DATE |
|-----------------|------------|
| DRAWN CA | 10/4/2019 |
| CHECKED JEM | 10/4/2019 |
| QA | |
| MFG | |
| ENGINEER CA | 10/14/2019 |
| APPROVED JEM | 10/4/2019 |

The PHOENIX Company of Chicago, Inc.

22 GREAT HILL RD., NAUGATUCK, CT 06770
WWW.PHOENIXOFCHICAGO.COM
PHONE: (800) 323-9562 FAX:(630) 206-1801

TITLE
PkZ® RECEPTACLE, DIRECT SOLDER TERMINATION

| | | | | |
|------------------|---------------|-------------------------------|----------|----------------------------|
| SIZE B | FSCM 58167 | DWG NO 78-1020-1413 | REV D | PLATING OPT. A, B, C, D |
| SCALE 3 : 1 | F.S.R. # | SHEET 1 OF 1 | | |

4

3

2

1