

4

3

2

1

B

B

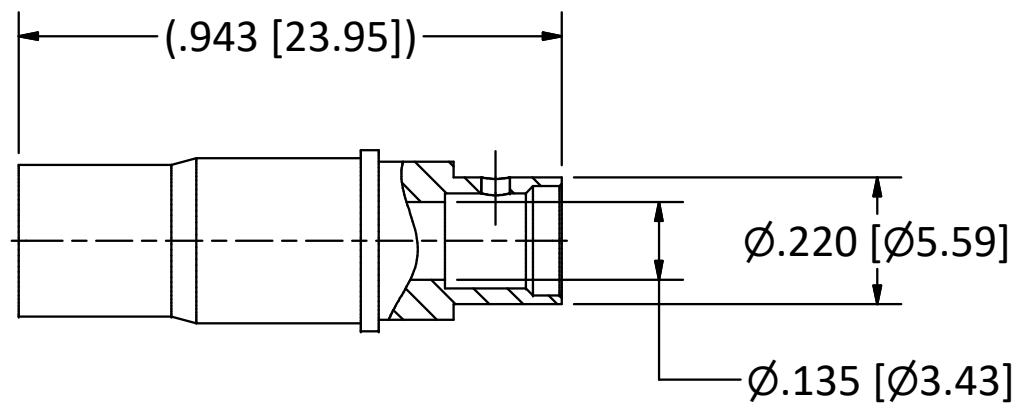

NOTES:

- 1. SPECIFICATION PER IDS-78.
- 2. ACCOMMODATES TIMES SFT-142B CABLE.
- HOUSING:** MIL-C-38999 SERIES I, III, & IV AND MIGHTY MOUSE SERIES 80, SIZE 8 CAVITY.

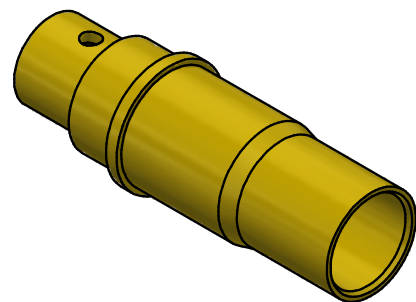

SCALE 2.5 : 1

4

3

2

1

A

A

				<p>This drawing embodies a proprietary design of The Phoenix Company of Chicago, Inc., Naugatuck, CT 06770. All design, manufacturing, reproduction, use, sale, and other rights regarding the same are expressly reserved. The information in this drawing may be covered completely or in part by patents and/or patents pending.</p>	<p>WARNING - THIS DOCUMENT CONTAINS TECHNICAL DATA WHOSE EXPORT IS RESTRICTED BY THE ARMS EXPORT CONTROL ACT (TITLE 22, U.S.C., SEC 2751, ET. SEQ.) OR THE EXPORT ADMINISTRATION ACT OF 1979, AS AMENDED, TITLE 50, U.S.C., APP 2401 ET SEQ. VIOLATIONS OF THESE EXPORT LAWS ARE SUBJECT TO SEVERE CRIMINAL PENALTIES. DISSEMINATE IN ACCORDANCE WITH PROVISIONS OF DOD DIRECTIVE 5230.25.</p>	<p>Filename: ver2\Autodesk Inventor Data Base\Assemblies\78 Series\78-1020-2202-CU.idw</p>		<p>The PHOENIX Company of Chicago, Inc. 22 GREAT HILL RD., NAUGATUCK, CT 06770 WWW.PHOENIXOFCHICAGO.COM PHONE: (800) 323-9562 FAX:(630) 206-1801</p>				
		UNLESS OTHERWISE SPECIFIED, PHOENIX WORKMANSHIP STANDARDS APPLY DIMENSIONS IN INCHES OR (METRIC)	APPROVALS			DATE						
C	PER ECN 13471	8/23/19	JEM									
B	PER ECN 12956	5/24/18	JEM									
A	PER ECN 12270	1/18/16	JEM									
01	PRELIMINARY	8/3/10	JEM									
REV	DESCRIPTION	DATE	BY			DO NOT SCALE PRINTS		TOLERANCES ARE: FRACTIONS: ± 1/64 DECIMALS: .XX ± .01 .XXX ± .003 ANGLES: ± 1/2°				
				ENGINEER	8/23/2019	TITLE		SIZE	FSCM	DWG NO	REV	PLATING OPT.
				APPROVED	8/23/2019	PkZ® RECEPTACLE, DIRECT SOLDER TERMINATION		B	58167	78-1020-2202	C	A, B, C, D
						SCALE 3 : 1		F.S.R. #		SHEET 1 OF 1		