

4

3

2

1

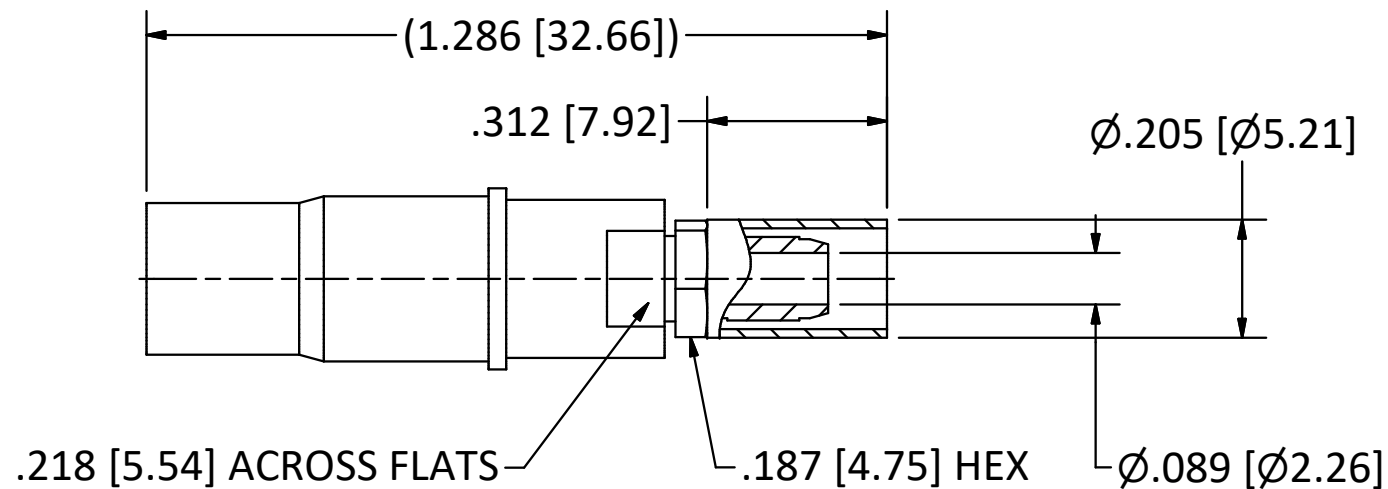
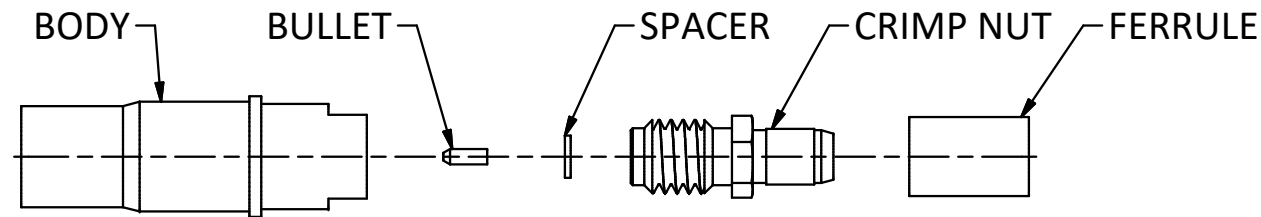

NOTES:

- 1. SPECIFICATIONS PER IDS-78.
 - 2. BULLET, CRIMP NUT, FERRULE, AND SPACER SHIPPED LOOSE.
 - 3. ACCOMMODATES SUHNER 2_O2162_B CABLE.
 - 4. CRIMP USING .178 HEX DIE (M22520/5-05).
- HOUSING:** MIL-C-38999 SERIES I, III, & IV AND MIGHTY MOUSE SERIES 80, SIZE 8 CAVITY.

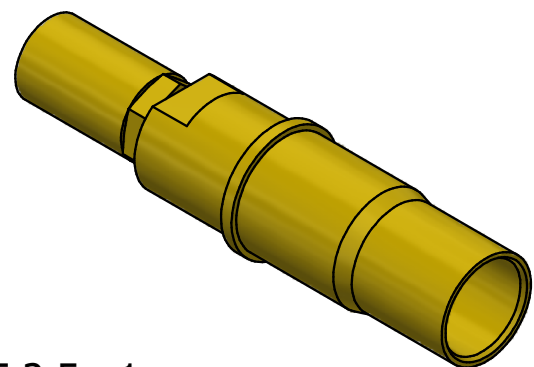

SCALE 2.5 : 1

D	PER ECN 13531	10/15/19	JEM
C	PER ECN 10596	9/8/10	MS
B	PER ECN 10406	6/4/10	JEM
A	PER ECN 10261	4/5/10	JEM
REV	DESCRIPTION	DATE	BY

This drawing embodies a proprietary design of The Phoenix Company of Chicago, Inc., Naugatuck, CT 06770. All design, manufacturing, reproduction, use, sale, and other rights regarding the same are expressly reserved. The information in this drawing may be covered completely or in part by patents and/or patents pending.

WARNING - THIS DOCUMENT CONTAINS TECHNICAL DATA WHOSE EXPORT IS RESTRICTED BY THE ARMS EXPORT CONTROL ACT (TITLE 22, U.S.C., SEC 2751, ET. SEQ.) OR THE EXPORT ADMINISTRATION ACT OF 1979, AS AMENDED, TITLE 50, U.S.C., APP 2401 ET SEQ. VIOLATIONS OF THESE EXPORT LAWS ARE SUBJECT TO SEVERE CRIMINAL PENALTIES. DISSEMINATE IN ACCORDANCE WITH PROVISIONS OF DOD DIRECTIVE 5230.25.

Filename: ver2\Autodesk Inventor Data Base\Assemblies\78 Series\78-1080-1082-CU.idw

UNLESS OTHERWISE SPECIFIED, PHOENIX WORKMANSHIP STANDARDS APPLY DIMENSIONS IN INCHES OR (METRIC)

DO NOT SCALE PRINTS
TOLERANCES ARE:
FRACTIONS: ± 1/64
DECIMALS: .XX ± .01
.XXX ± .003
ANGLES: ± 1/2°

APPROVALS	DATE
DRAWN CA	10/15/2019
CHECKED JEM	10/15/2019
QA	
MFG	
ENGINEER CA	10/15/2019
APPROVED JEM	10/15/2019

The PHOENIX Company of Chicago, Inc.

22 GREAT HILL RD., NAUGATUCK, CT 06770
WWW.PHOENIXOFCHICAGO.COM
PHONE: (800) 323-9562 FAX:(630) 206-1801

TITLE PKZ® RECEPTACLE, CRIMP/CLAMP TERMINATION					
SIZE B	FSCM 58167	DWG NO 78-1080-1082	REV D	PLATING OPT. A, B, C, D	
SCALE 3 : 1	F.S.R. #	SHEET 1 OF 1			

4

3

2

1