

4

3

2

1

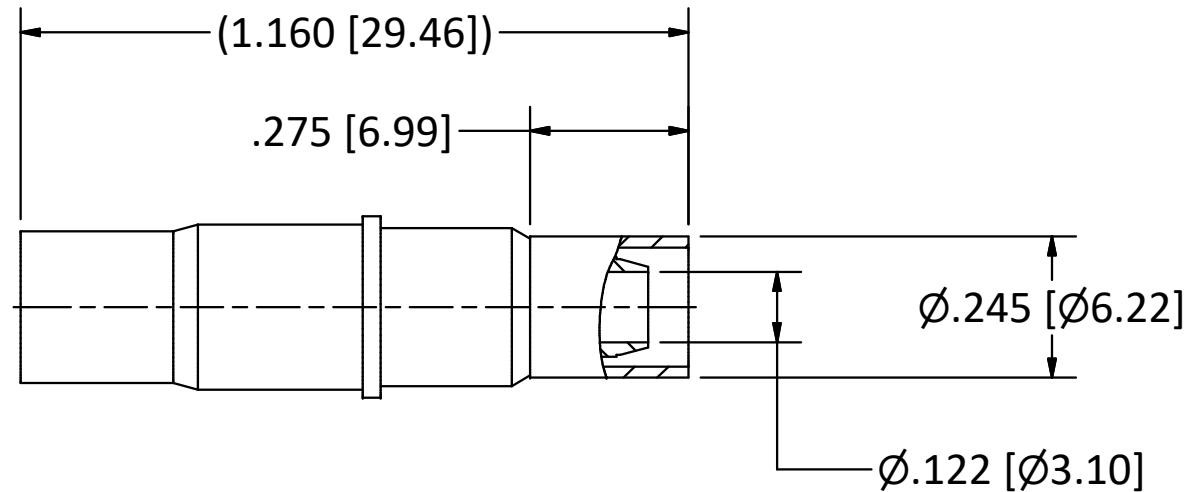
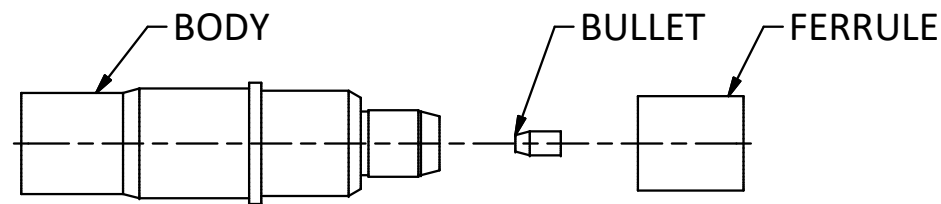

NOTES:

- 1. SPECIFICATIONS PER IDS-78.
- 2. BULLET AND FERRULE SHIPPED LOOSE.
- 3. ACCOMMODATES RG-400 CABLE.
- 4. CRIMP USING .213 HEX DIE SET Y-197 M22520/5-05.

HOUSING: MIL-C-38999 SERIES I, III, & IV AND MIGHTY MOUSE SERIES 80, SIZE 8 CAVITY.

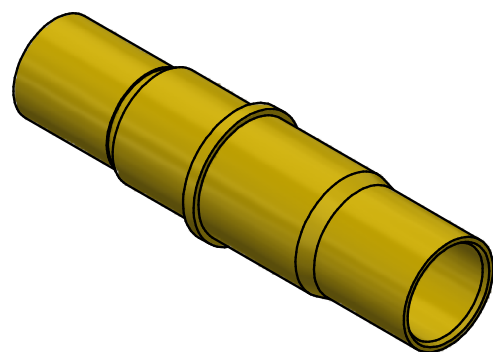

SCALE 2.5 : 1

REV	DESCRIPTION	DATE	BY
E	PER ECN 13536	13/16/19	JEM
D	PER ECN 9680	3/25/02	JEM
C	PER ECN 6604	5/7/02	HN
B	PER ECN 6516	3/25/02	HN
A	PER ECN 6420	12/12/01	HN

This drawing embodies a proprietary design of The Phoenix Company of Chicago, Inc., Naugatuck, CT 06770. All design, manufacturing, reproduction, use, sale, and other rights regarding the same are expressly reserved. The information in this drawing may be covered completely or in part by patents and/or patents pending.

WARNING - THIS DOCUMENT CONTAINS TECHNICAL DATA WHOSE EXPORT IS RESTRICTED BY THE ARMS EXPORT CONTROL ACT (TITLE 22, U.S.C., SEC 2751, ET. SEQ.) OR THE EXPORT ADMINISTRATION ACT OF 1979, AS AMENDED, TITLE 50, U.S.C., APP 2401 ET SEQ. VIOLATIONS OF THESE EXPORT LAWS ARE SUBJECT TO SEVERE CRIMINAL PENALTIES. DISSEMINATE IN ACCORDANCE WITH PROVISIONS OF DOD DIRECTIVE 5230.25.

Filename: ver2\Autodesk Inventor Data Base\Assemblies\78 Series\78-1080-1203-CU.idw

UNLESS OTHERWISE SPECIFIED, PHOENIX WORKMANSHIP STANDARDS APPLY DIMENSIONS IN INCHES OR (METRIC)

DO NOT SCALE PRINTS
TOLERANCES ARE:
FRACTIONS: ± 1/64
DECIMALS: .XX ± .01
.XXX ± .003
ANGLES: ± 1/2°



APPROVALS	DATE
DRAWN CA	10/16/2019
CHECKED JEM	10/16/2019
QA	
MFG	
ENGINEER CA	10/16/2019
APPROVED JEM	10/16/2019

The PHOENIX Company of Chicago, Inc.

22 GREAT HILL RD., NAUGATUCK, CT 06770
WWW.PHOENIXOFCHICAGO.COM
PHONE: (800) 323-9562 FAX:(630) 206-1801

TITLE
PkZ® RECEPTACLE, CRIMP TERMINATION

SIZE	FSCM	DWG NO	REV	PLATING OPT.
B	58167	78-1080-1203	E	A, B, C, D
SCALE	3 : 1	F.S.R. #	SHEET	1 OF 1

4

3

2

1