

4

3

2

1

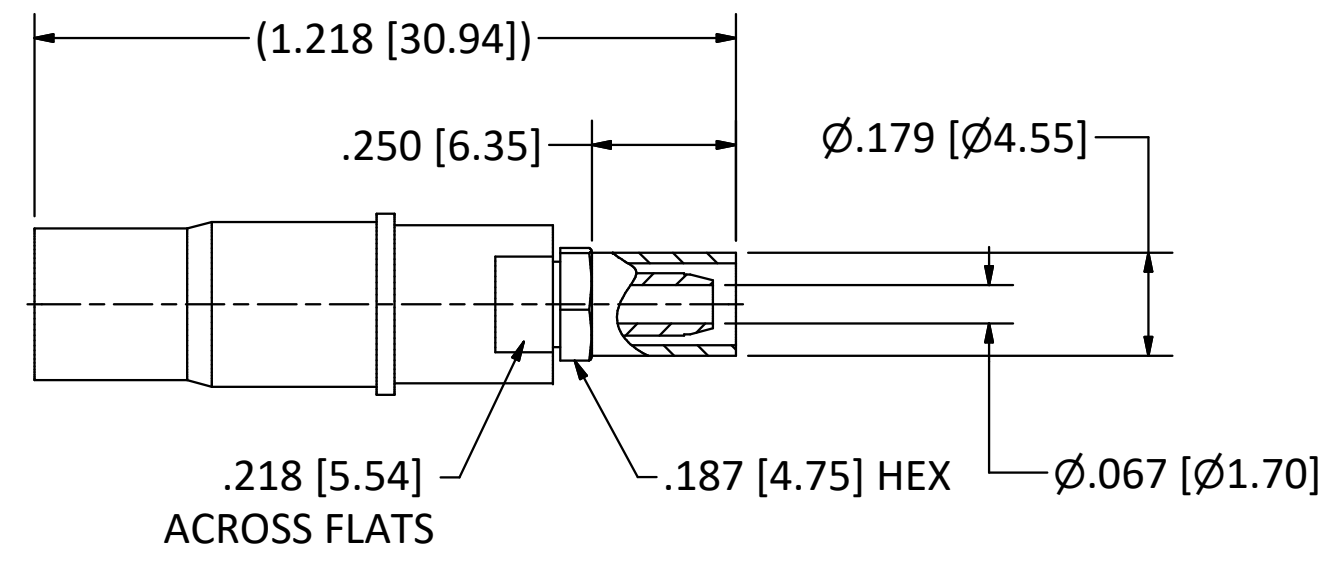
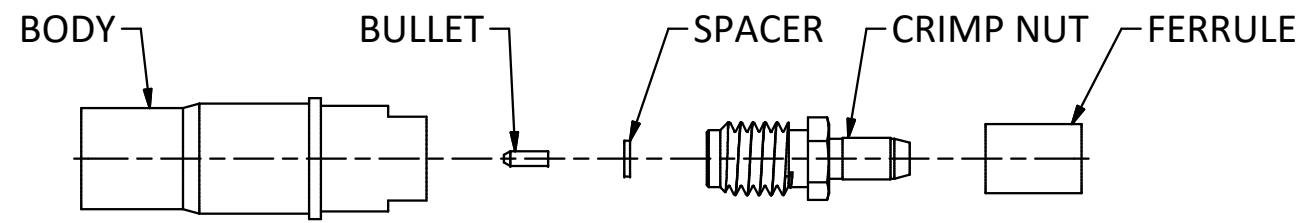

- NOTES:
1. SPECIFICATIONS PER IDS-78.
 2. BULLET, CRIMP NUT, FERRULE, AND SPACER SHIPPED LOOSE.
 3. ACCOMMODATES RG-316 DOUBLE SHIELD (M17/152) CABLE.
 4. CRIMP USING .151 HEX DIE (M22520/5-37).
- HOUSING:** MIL-C-38999 SERIES I, III, & IV AND MIGHTY MOUSE SERIES 80, SIZE 8 CAVITY.

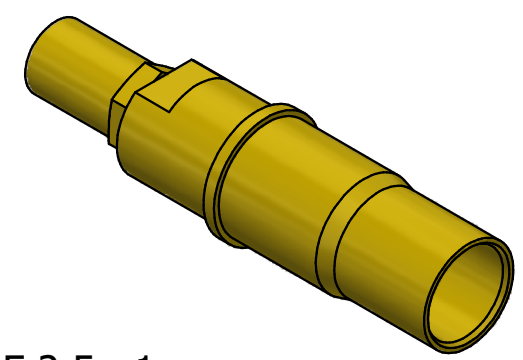

SCALE 2.5 : 1

REV	DESCRIPTION	DATE	BY
E	PER ECN 13489	9/12/19	JEM
D	PER ECN 12958	5/24/18	JEM
C	PER ECN 10471	7/20/10	JEM
B	PER ECN 9678	12/08/08	JEM
A	REL ECN 6620	5/16/02	HN

This drawing embodies a proprietary design of The Phoenix Company of Chicago, Inc., Naugatuck, CT 06770. All design, manufacturing, reproduction, use, sale, and other rights regarding the same are expressly reserved. The information in this drawing may be covered completely or in part by patents and/or patents pending.

WARNING - THIS DOCUMENT CONTAINS TECHNICAL DATA WHOSE EXPORT IS RESTRICTED BY THE ARMS EXPORT CONTROL ACT (TITLE 22, U.S.C., SEC 2751, ET. SEQ.) OR THE EXPORT ADMINISTRATION ACT OF 1979, AS AMENDED, TITLE 50, U.S.C., APP 2401 ET SEQ. VIOLATIONS OF THESE EXPORT LAWS ARE SUBJECT TO SEVERE CRIMINAL PENALTIES. DISSEMINATE IN ACCORDANCE WITH PROVISIONS OF DOD DIRECTIVE 5230.25.

Filename: ver2\Autodesk Inventor Data Base\Assemblies\78 Series\78-1080-2670-CU.idw		
UNLESS OTHERWISE SPECIFIED, PHOENIX WORKMANSHIP STANDARDS APPLY DIMENSIONS IN INCHES OR (METRIC)	APPROVALS	DATE
	DRAWN CA	9/12/2019
DO NOT SCALE PRINTS	CHECKED JEM	9/12/2019
	QA	
TOLERANCES ARE: FRACTIONS: ± 1/64 DECIMALS: .XX ± .01 .XXX ± .003 ANGLES: ± 1/2°	MFG	
	ENGINEER CA	9/12/2019
32√	APPROVED JEM	10/18/2019

The PHOENIX Company of Chicago, Inc.			
22 GREAT HILL RD., NAUGATUCK, CT 06770 WWW.PHOENIXOFCHICAGO.COM PHONE: (800) 323-9562 FAX:(630) 206-1801			
TITLE PKZ® RECEPTACLE, CRIMP/CLAMP TERMINATION			
SIZE B	FSCM 58167	DWG NO 78-1080-2670	REV E
SCALE 3 : 1	F.S.R. #	SHEET 1	PLATING OPT. A, B, C, D OF 1

4

3

2

1