

NOTES:

1.) MATERIALS:

HOUSING: NON-MAGNETIC BRASS
 HARDWARE: NON-MAGNETIC BRASS

2.) FINISHES:

HOUSING: GOLD PLATED
 HARDWARE: CORROSION RESISTANT

3.) DIMENSIONS ARE FOR REFERENCE ONLY,
 UNLESS OTHERWISE SPECIFIED.

4.) SEE INDIVIDUAL CABLE ASSEMBLY DRAWINGS
 FOR PERFORMANCE AND SPECIFICATIONS.

5.) MAGNETISM: < 1.00000 mu.

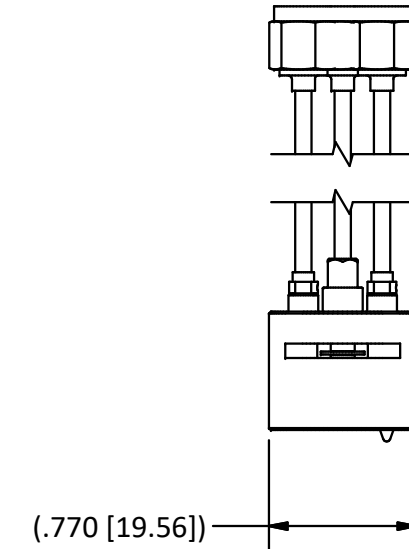
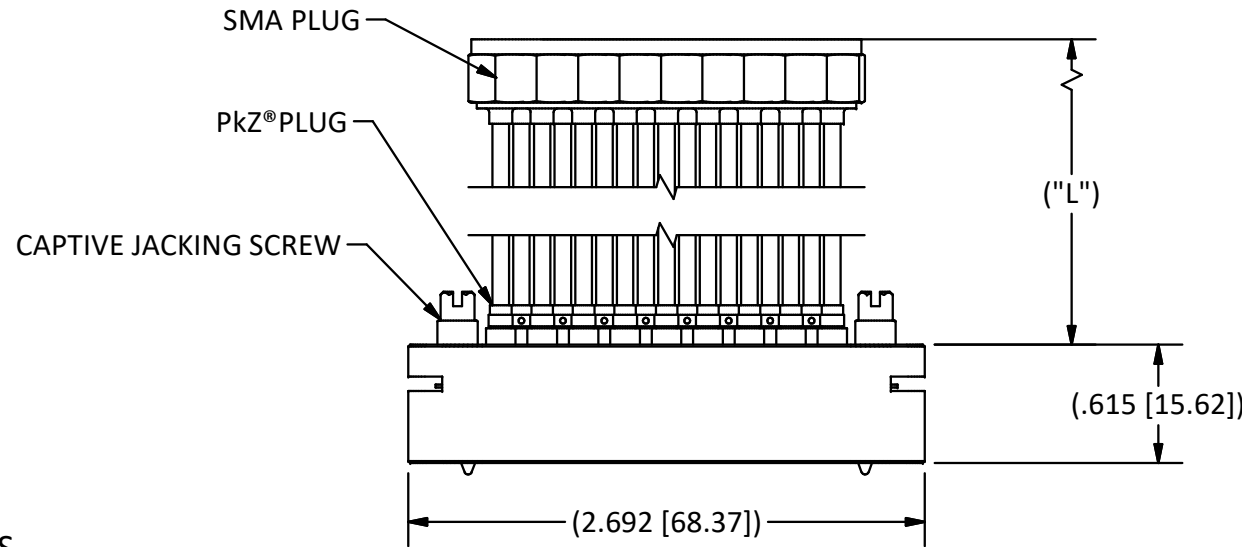

PART NUMBER HDQP03100-0201 SHOWN
 SCALE 1 : 1

Part Number	Description	"L" Cable Length
HDQP03100-0201	Quantum Plug Housing; 26 Position, 18 GHz, 8 Inch Cable Length	8"
HDQP03100-0202	Quantum Plug Housing; 26 Position, 18 GHz, 9 Inch Cable Length	9"
HDQP03100-0203	Quantum Plug Housing; 26 Position, 18 GHz, 12 Inch Cable Length	12"
HDQP03100-0204	Quantum Plug Housing; 26 Position, 18 GHz, 18 Inch Cable Length	18"
HDQP03100-0205	Quantum Plug Housing; 26 Position, 18 GHz, 24 Inch Cable Length	24"

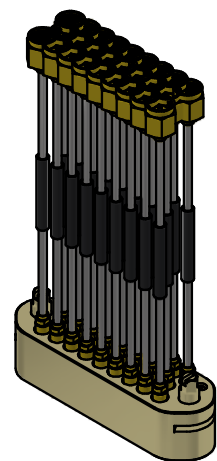

REV	DESCRIPTION	BY	DATE
A	ECN #14203	JR	2/8/2023

This drawing embodies a proprietary design of The Phoenix Company of Chicago, Inc., Naugatuck, CT 06770. All design, manufacturing, reproduction, use, sale, and other rights regarding the same are expressly reserved. The information in this drawing may be covered completely or in part by patents and/or patents pending.

WARNING - THIS DOCUMENT CONTAINS TECHNICAL DATA WHOSE EXPORT IS RESTRICTED BY THE ARMS EXPORT CONTROL ACT (TITLE 22, U.S.C., SEC 2751, ET. SEQ.) OR THE EXPORT ADMINISTRATION ACT OF 1979, AS AMENDED, TITLE 50, U.S.C., APP 2401 ET SEQ. VIOLATIONS OF THESE EXPORT LAWS ARE SUBJECT TO SEVERE CRIMINAL PENALTIES. DISSEMINATE IN ACCORDANCE WITH PROVISIONS OF DOD DIRECTIVE 5230.25.

Filename: B_C_Size_Formats.idw

UNLESS OTHERWISE SPECIFIED, PHOENIX WORKMANSHIP STANDARDS APPLY DIMENSIONS IN INCHES OR (METRIC)

DO NOT SCALE PRINTS
 TOLERANCES ARE:
 FRACTIONS: ± 1/64
 DECIMALS: .XX ± .01
 .XXX ± .003
 ANGLES: ± 1/2°

32

APPROVALS	DATE
DRAWN bprempas	5/5/2022
CHECKED RMB	2/8/2023
QA V.I.	2/8/2023
MFG SG	2/8/2023
ENGINEER A. HUEZO	2/8/2023
APPROVED RMB	2/8/2023

The PHOENIX Company of Chicago, Inc.

22 GREAT HILL RD., NAUGATUCK, CT 06770
 WWW.PHOENIXOFCHICAGO.COM
 PHONE: (800) 323-9562 FAX:(630) 206-1801

TITLE
**Quantum Plug Housing; 26 Position, 18 GHz,
 Fully Loaded With Cable Assemblies**

SIZE B	FSCM 58167	DWG NO HDQP03100-02XX	REV A	PLATING OPT.
SCALE 1 : 1	F.S.R. #	SHEET 1	OF 1	