

SPECIFICATIONS:

- 1) MATERIALS:  
 INSERT: VALOX, TYPE GPT-30F, PER MIL-M-24519  
 SHELL: COLD ROLLED STEEL, PER ASTM A568 AND ASTM A620
- 2) FINISHES AND COLOR:  
 INSERT: BLACK  
 SHELL: TIN, CLASS FE/SN8, (.0003000), PER ASTM B545
- 3) ELECTRICAL PROPERTIES:  
 DIELECTRIC STRENGTH: 500 TO 1,000 VOLTS RMS AT SEA LEVEL;  
 200 TO 325 VOLTS RMS AT 70,000 FEET  
 INSULATION RESISTANCE: 1 MEGOHM MINIMUM

- 4) MECHANICAL PROPERTIES:  
 OPERATING TEMPERATURE: -67°F TO +257°F (-55°C TO +125°C)  
 SHOCK RESISTANCE: NO INTERRUPTION OF ELECTRICAL CONTINUITY LONGER THAN 1 MICROSECOND.  
 VIBRATION RESISTANCE: NO INTERRUPTION OF ELECTRICAL CONTINUITY LONGER THAN 1 MICROSECOND.
- 5) DIMENSIONS ARE FOR REFERENCE ONLY, UNLESS OTHERWISE SPECIFIED.
- 6) CONNECTOR MEETS REQUIREMENTS OF MIL-C-24308, LATEST REVISION.
- 7) ABOVE REQUIREMENTS DO NOT INCLUDE PDM OR PKZ CONTACTS, PLEASE REFER TO INDIVIDUAL SPECIFICATION SHEETS.

REVISIONS			
REV	DESCRIPTION	DATE	APPROVED
A	RELEASED FOR PRODUCTION	9-03-15	AH

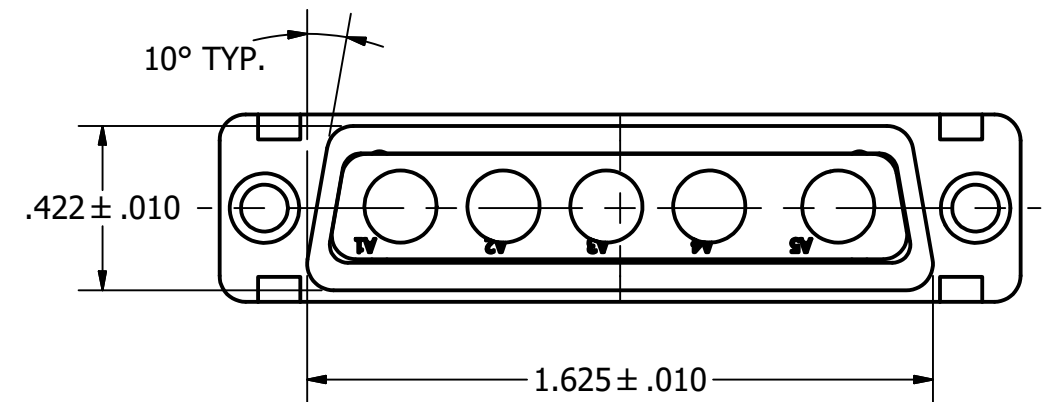
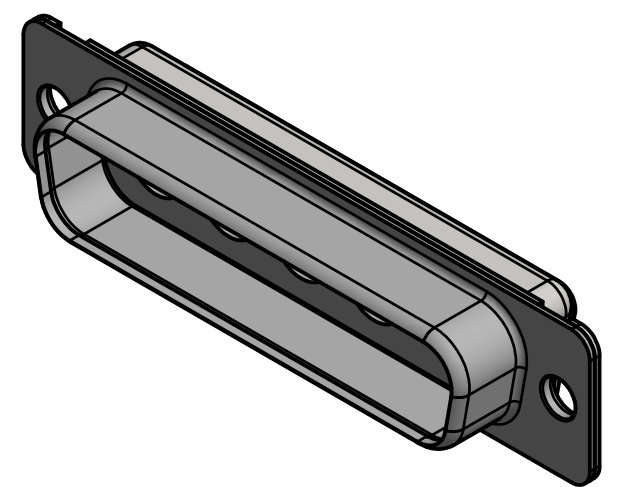
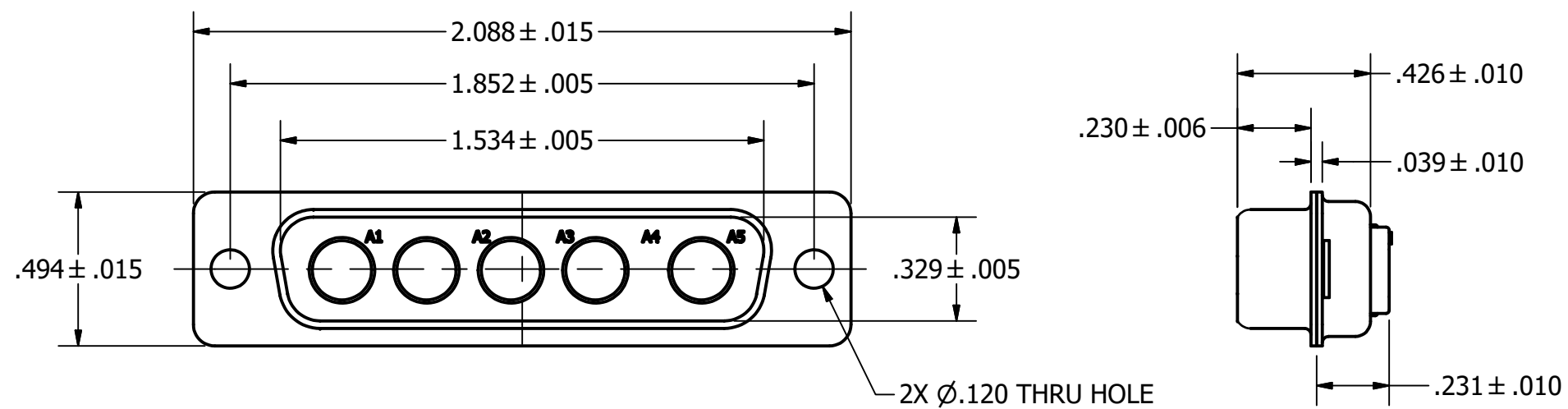

WARNING - THIS DOCUMENT CONTAINS TECHNICAL DATA WHOSE EXPORT IS RESTRICTED BY THE ARMS EXPORT CONTROL ACT (TITLE 22, U.S.C., SEC 2751, ET. SEQ.) OR THE EXPORT ADMINISTRATION ACT OF 1979, AS AMENDED, TITLE 50, U.S.C., APP 2401 ET SEQ. VIOLATIONS OF THESE EXPORT LAWS ARE SUBJECT TO SEVERE CRIMINAL PENALTIES. DISSEMINATE IN ACCORDANCE WITH PROVISIONS OF DOD DIRECTIVE 5230.25.

NEXT ASSEMBLY	USED ON
APPLICATIONS	

UNLESS OTHERWISE SPECIFIED DIMENSIONS ARE IN INCHES TOLERANCES ARE:  
 FRACTIONS ±1/64    DECIMALS .XX ±.01    ANGLES ±1/2°  
 .XXX ±.003

THE INFORMATION DISCLOSED IN THIS DOCUMENT IS CONFIDENTIAL AND PROPRIETARY TO PHOENIX CO. INC. AND MAY NOT BE USED FOR MANUFACTURE OR ANY OTHER PURPOSE WITHOUT THE WRITTEN CONSENT OF PHOENIX CO. INC.

DO NOT SCALE DRAWING

CONTRACT NO.	
APPROVALS	DATE
DRAWN A. Huezo	09/03/15
CHECKED A. Huezo	09/03/15
ISSUED	

*The PHOENIX Company of Chicago* <sup>TM</sup>

**DSUB CONNECTOR; 5W5 PLUG, STD MOUNTING**

**TIN PLATED**

SIZE <b>B</b>	FSCM NO. <b>60563</b>	DWG. NO. <b>P55P3</b>	REV. <b>A</b>
------------------	--------------------------	--------------------------	------------------

SCALE **2:1**      SHEET **1** OF **1**