

4

3

2

1

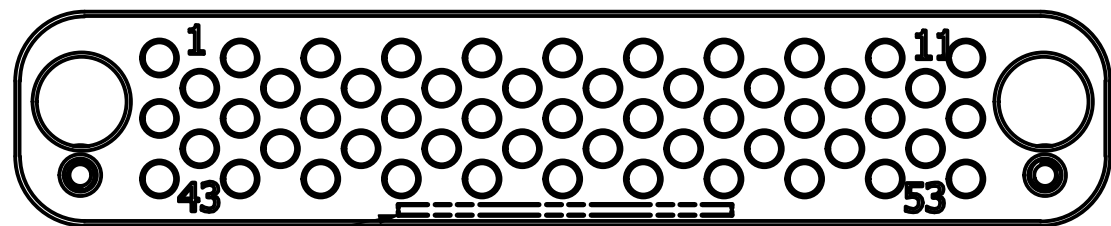

BACK VIEW

NOTE 1

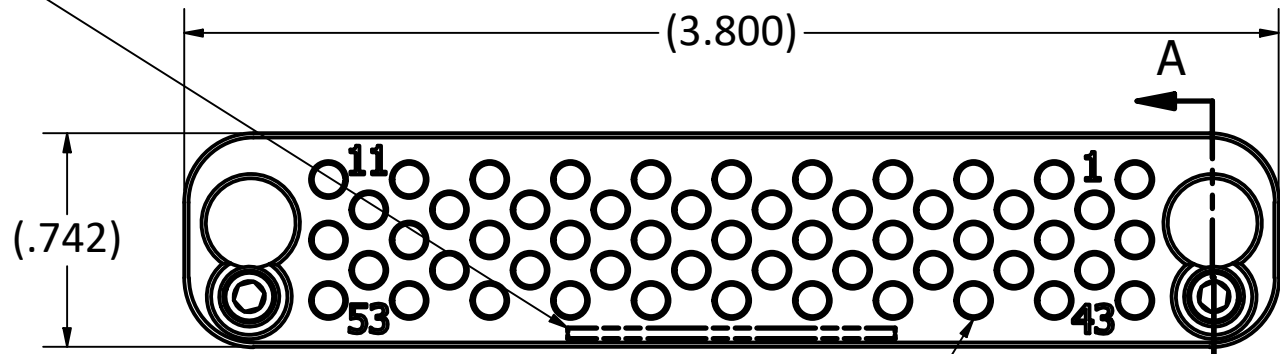

FRONT VIEW

SEE TABLE FOR HOLE SIZE

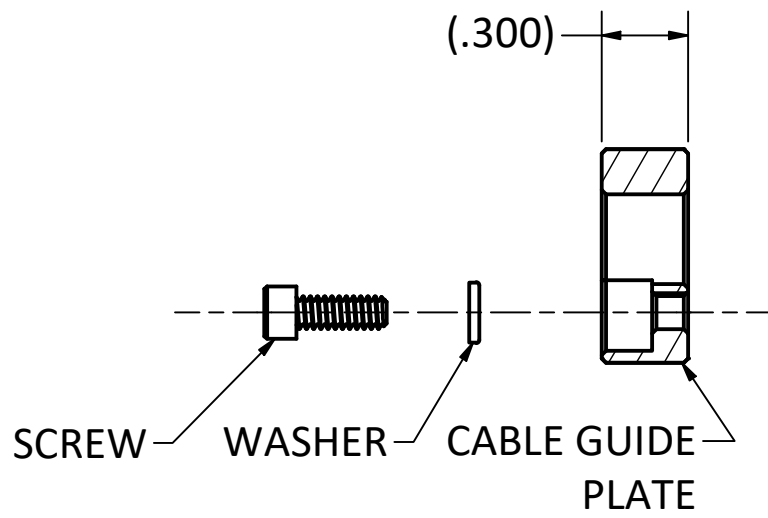

SECTION A-A

SPECIFICATIONS:

1. PART NUMBER: SEE TABLE
CABLE GUIDE PLATE PART NUMBER MARKED IN LOCATION INDICATED
2. MATERIALS:
 - a) GUIDE PLATE: ACETAL, COLOR: BLACK.
 - b) MOUNTING HARDWARE: STAINLESS STEEL.
3. HARDWARE FINISHES: PASSIVATED
4. ENVIRONMENTAL PROPERTIES:
OPERATING TEMPERATURE: -40° F TO +194° F (-40° C TO +90° C).
5. MOUNTING HARDWARE SUPPLIED LOOSE.

PX16FGPK04	Ø .058	.047 CABLE	156-0302-0470
PX16FGPK03	Ø .082	1.37MM, RG-178, RG-196	156-0202-0402
PX16FGPK02	Ø .117	RG-174, RG-179, RG-189, RG-316	156-0202-0671
PX16FGPK01	Ø .109	RG405	156-0302-0861
PHOENIX P/N	MAXIMUM CABLE DIAMETER (REFERENCE)	CABLE REFERENCE	PKZ REFERENCE PLUG

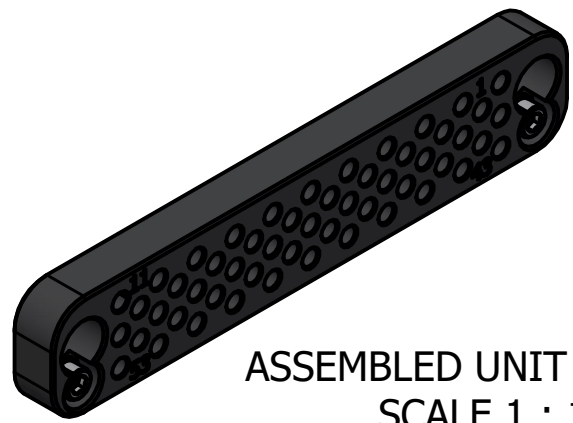

ASSEMBLED UNIT SHOWN
SCALE 1 : 1

A	RELEASED PER ECN 14489	2/25/2025	AH
01	PRELIMINARY	1/10/2025	WP
REV.	DESCRIPTION	DATE	APPROVAL

This drawing embodies a proprietary design of The Phoenix Company of Chicago, Inc., Naugatuck, CT 06770. All design, manufacturing, reproduction, use, sale, and other rights regarding the same are expressly reserved. The information in this drawing may be covered completely or in part by patents and/or patents pending.

WARNING - THIS DOCUMENT CONTAINS TECHNICAL DATA WHOSE EXPORT IS RESTRICTED BY THE ARMS EXPORT CONTROL ACT (TITLE 22, U.S.C., SEC 2751, ET. SEQ.) OR THE EXPORT ADMINISTRATION ACT OF 1979, AS AMENDED, TITLE 50, U.S.C., APP 2401 ET SEQ. VIOLATIONS OF THESE EXPORT LAWS ARE SUBJECT TO SEVERE CRIMINAL PENALTIES. DISSEMINATE IN ACCORDANCE WITH PROVISIONS OF DOD DIRECTIVE 5230.25.

UNLESS OTHERWISE SPECIFIED, PHOENIX WORKMANSHIP STANDARDS APPLY DIMENSIONS IN INCHES OR [METRIC] DO NOT SCALE PRINTS TOLERANCES ARE: FRACTIONS: ± 1/64 DECIMALS: .XX ± .01 .XXX ± .003 ANGLES: ± 1/2°	APPROVALS	DATE
	DRAWN WP	12/04/2024
	CHECKED AH	12/04/2024
	QA JB	2/25/2025
	MFG VL	2/25/2025
ENGINEER WP	02/05/2025	
APPROVED A.H	02/05/2025	

The PHOENIX Company of Chicago, Inc.
 22 GREAT HILL RD., NAUGATUCK, CT 06770
 WWW.PHOENIXOFCHICAGO.COM
 PHONE: (800) 323-9562 FAX:(630) 206-1801

TITLE
PX CABLE, 53 POSITION GUIDE PLATE KIT

SIZE B	FSCM 58167	DWG NO PX16FGPKXX	REV A	PLATING OPT.
SCALE 1.5:1	F.S.R. #	SHEET 1	OF 1	

4

3

2

1