

**SPECIFICATIONS:**

1. PART NUMBER: PX16FRDDYAV200C AND DATE CODE
2. MATERIALS:
  - a) HOUSING: ACETAL, COLOR: BLACK
  - b) HARDWARE (JACKSOCKETS, NUTS AND WASHERS): STAINLESS STEEL
3. HARDWARE FINISHES: PASSIVATED.
4. ELECTRICAL PROPERTIES (APPLIES TO HOUSING ONLY):
  - a) DIELECTRIC STRENGTH: 1,000 VOLTS RMS AT SEA LEVEL;  
325 VOLTS RMS AT 70,000 FEET.
  - b) INSULATION RESISTANCE: 1 MEGOHM MINIMUM.
5. ENVIRONMENTAL PROPERTIES:
  - OPERATING TEMPERATURE: -40° F TO +194° F ( -40° C TO +90° C ).
6. CABLE ASSEMBLY SPECIFICATIONS:
  - a) IMPEDANCE 50 OHMS
  - b) HI-POT & CONTINUITY TEST 100%.
  - c) PKZ SPECIFICATIONS PER IDS-156.
  - d) FREQUENCY: DC TO 6 GHz

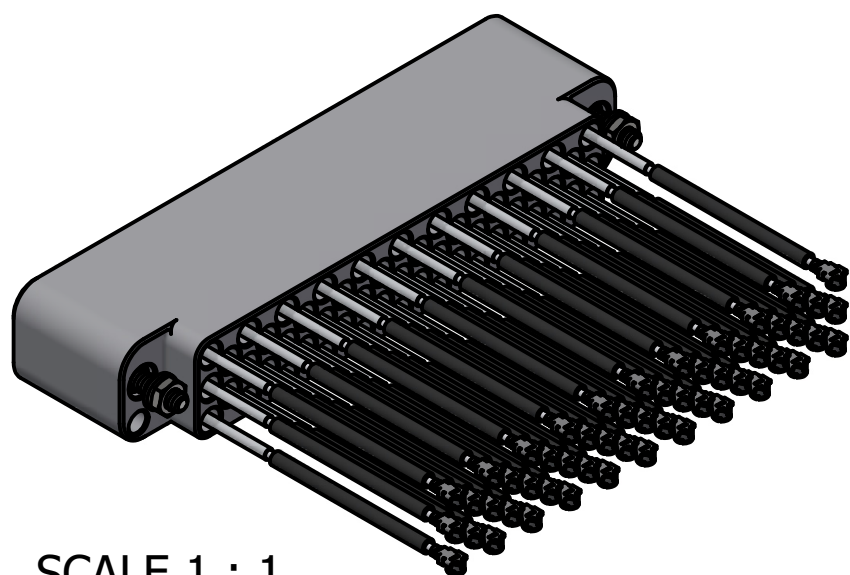
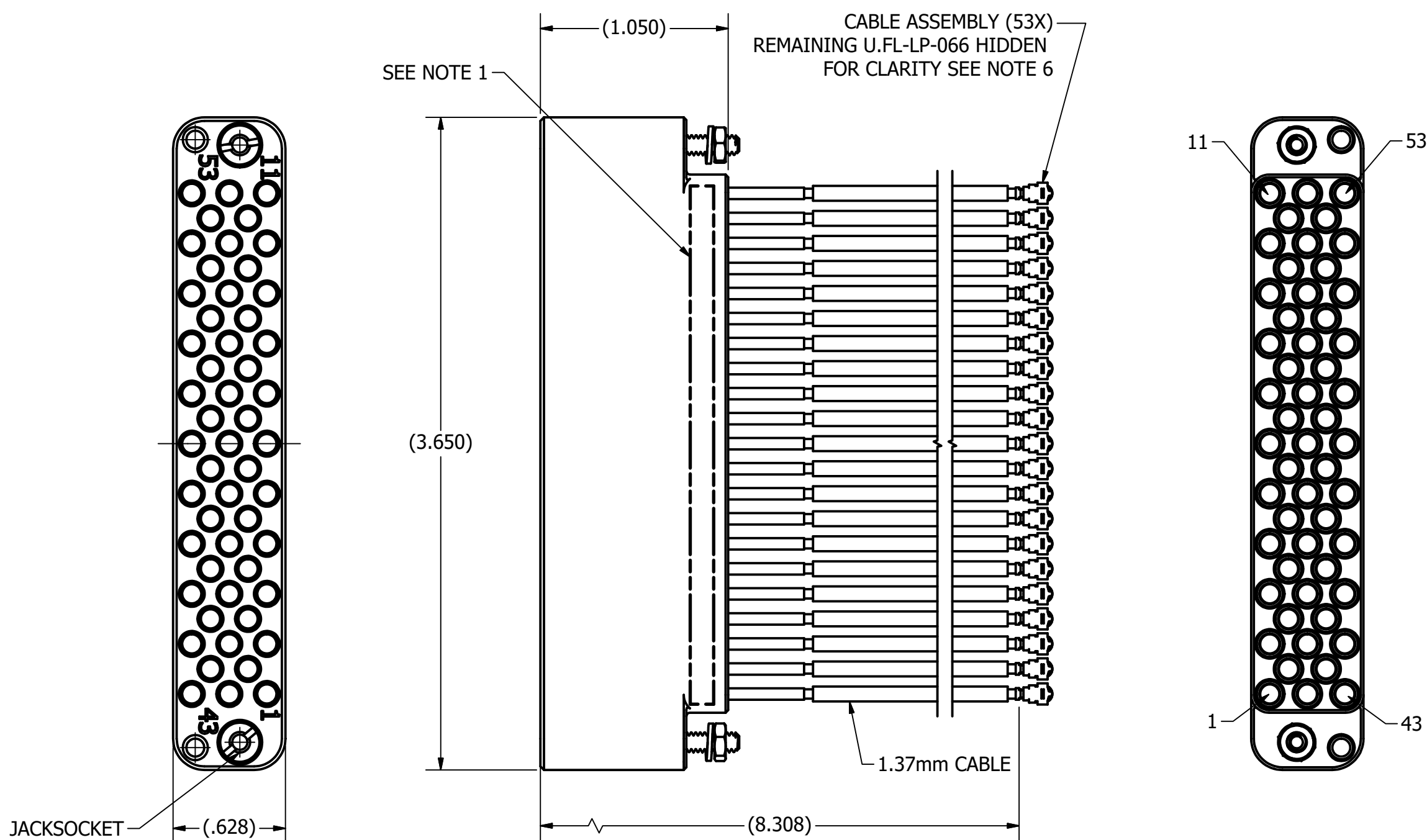
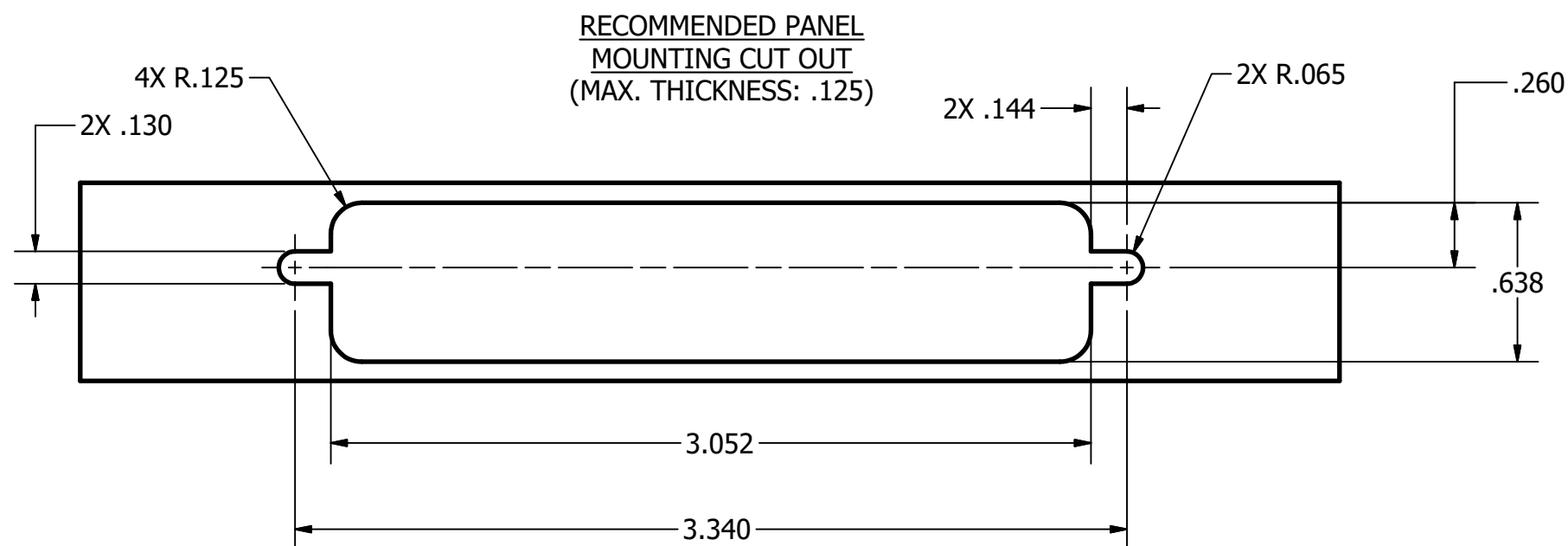

SCALE 1 : 1

| MATERIAL:  |                        | <p><b>WARNING - THIS DOCUMENT CONTAINS TECHNICAL DATA WHOSE EXPORT IS RESTRICTED BY THE ARMS EXPORT CONTROL ACT (TITLE 22, U.S.C., SEC 2751, ET. SEQ.) OR THE EXPORT ADMINISTRATION ACT OF 1979, AS AMENDED, TITLE 50, U.S.C., APP 2401 ET SEQ. VIOLATIONS OF THESE EXPORT LAWS ARE SUBJECT TO SEVERE CRIMINAL PENALTIES. DISSEMINATE IN ACCORDANCE WITH PROVISIONS OF DOD DIRECTIVE 5230.25.</b></p> <p><b>This drawing embodies a proprietary design of The Phoenix Company of Chicago, Inc., Naugatuck, CT 06770. All design, manufacturing, reproduction, use, sale, and other rights regarding the same are expressly reserved. The information in this drawing may be covered completely or in part by patents and/or patents pending.</b></p> |             | <p><b>UNLESS OTHERWISE SPECIFIED, PALCO WORKMANSHIP STANDARDS APPLY DIMENSIONS IN INCHES OR (METRIC)</b></p> <p>DO NOT SCALE PRINTS</p> <p>TOLERANCES ARE:<br/>FRACTIONS: ± 1/64<br/>DECIMALS: .XX ± .01<br/>.XXX ± .003<br/>ANGLES: ± 1/2°</p> |          | <p><b>APPROVALS</b></p> <table border="1"> <tr> <th>APPROVALS</th> <th>DATE</th> </tr> <tr> <td>DRAWN<br/>WP</td> <td>9/25/2024</td> </tr> <tr> <td>CHECKED<br/>AH</td> <td>9/25/2024</td> </tr> <tr> <td>QA<br/>JB</td> <td>2/25/2025</td> </tr> <tr> <td>MFG<br/>VL</td> <td>2/26/2025</td> </tr> <tr> <td>ENGINEER<br/>AH</td> <td>2/25/2025</td> </tr> <tr> <td>APPROVED<br/>AH</td> <td>2/25/2025</td> </tr> </table> |                        | APPROVALS | DATE | DRAWN<br>WP  | 9/25/2024 | CHECKED<br>AH              | 9/25/2024 | QA<br>JB | 2/25/2025 | MFG<br>VL | 2/26/2025 | ENGINEER<br>AH | 2/25/2025 | APPROVED<br>AH | 2/25/2025 | <p><b>The PHOENIX Company of Chicago, Inc.</b></p> <p>22 GREAT HILL RD., NAUGATUCK, CT 06770<br/>WWW.PHOENIXOFCHICAGO.COM<br/>PHONE: (800) 323-9562 FAX:(630) 206-1801</p> |  |
|--|------------------------|--|-------------|---|----------|--|------------------------|-----------|------|--|-----------|----------------------------|-----------|----------|-----------|-----------|-----------|----------------|-----------|----------------|-----------|--|--|
| APPROVALS  | DATE                   |  |             |   |          |  |                        |           |      |  |           |                            |           |          |           |           |           |                |           |                |           |  |  |
| DRAWN<br>WP  | 9/25/2024              |  |             |   |          |  |                        |           |      |  |           |                            |           |          |           |           |           |                |           |                |           |  |  |
| CHECKED<br>AH  | 9/25/2024              |  |             |   |          |  |                        |           |      |  |           |                            |           |          |           |           |           |                |           |                |           |  |  |
| QA<br>JB   | 2/25/2025              |  |             |   |          |  |                        |           |      |  |           |                            |           |          |           |           |           |                |           |                |           |  |  |
| MFG<br>VL  | 2/26/2025              |  |             |   |          |  |                        |           |      |  |           |                            |           |          |           |           |           |                |           |                |           |  |  |
| ENGINEER<br>AH   | 2/25/2025              |  |             |   |          |  |                        |           |      |  |           |                            |           |          |           |           |           |                |           |                |           |  |  |
| APPROVED<br>AH   | 2/25/2025              |  |             |   |          |  |                        |           |      |  |           |                            |           |          |           |           |           |                |           |                |           |  |  |
|  |                        | <p><b>TITLE</b></p> <p>PX RECEPTABLE PANEL MOUNT HARNESS,<br/>53 POSITION, SIZE 16 PKZ® TO U.FL ON<br/>1.37 CABLE</p>  |             | <p><b>SIZE</b> C</p> <p><b>FSCM</b> 58167</p> <p><b>DWG NO</b> PX16FRDDYAV200C</p> <p><b>REV</b> A</p> <p><b>PLATING OPT.</b></p>   |          |  |                        |           |      |  |           |                            |           |          |           |           |           |                |           |                |           |  |  |
| <table border="1"> <tr> <th>REV.</th> <th>DESCRIPTION</th> <th>DATE</th> <th>APPROVAL</th> </tr> <tr> <td>A</td> <td>RELEASED PER ECN 14489</td> <td>2/25/2025</td> <td>AH</td> </tr> </table> |                        | REV.   | DESCRIPTION | DATE  | APPROVAL | A  | RELEASED PER ECN 14489 | 2/25/2025 | AH   | <p><b>SCALE</b> 1.5 : 1</p> <p><b>F.S.R. #</b></p> |           | <p><b>SHEET</b> 1 OF 1</p> |           |          |           |           |           |                |           |                |           |  |  |
| REV.   | DESCRIPTION            | DATE   | APPROVAL    |   |          |  |                        |           |      |  |           |                            |           |          |           |           |           |                |           |                |           |  |  |
| A  | RELEASED PER ECN 14489 | 2/25/2025  | AH          |   |          |  |                        |           |      |  |           |                            |           |          |           |           |           |                |           |                |           |  |  |