

RECOMMENDED PANEL MOUNTING CUT OUT (MAX. THICKNESS: .125)

SPECIFICATIONS:

1. PART NUMBER: PX16FRDX0XA0000 AND DATE CODE.
2. MATERIALS:
 - a) HOUSING: ACETAL, COLOR: BLACK.
 - b) HOUSING HARDWARE: STAINLESS STEEL.
3. HARDWARE FINISHES: PASSIVATED
4. ELECTRICAL PROPERTIES (APPLIES TO HOUSING ONLY):
 - a) DIELECTRIC STRENGTH: 1,000 VOLTS RMS AT SEA LEVEL; 325 VOLTS RMS AT 70,000 FEET.
 - b) INSULATION RESISTANCE: 1 MEGOHM MINIMUM.
5. ENVIRONMENTAL PROPERTIES:
 - OPERATING TEMPERATURE: -40° F TO +194° F (-40° C TO +90° C).

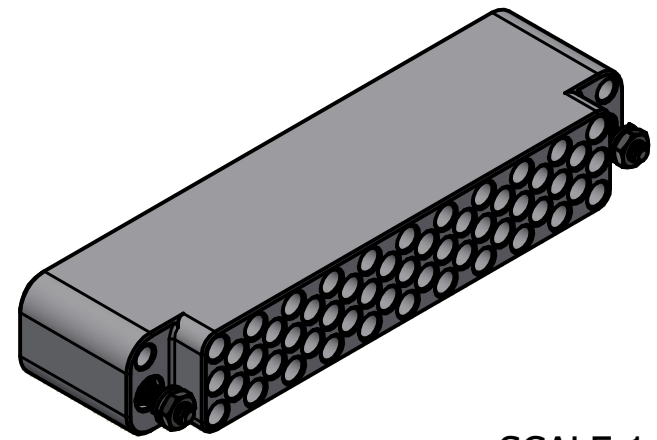
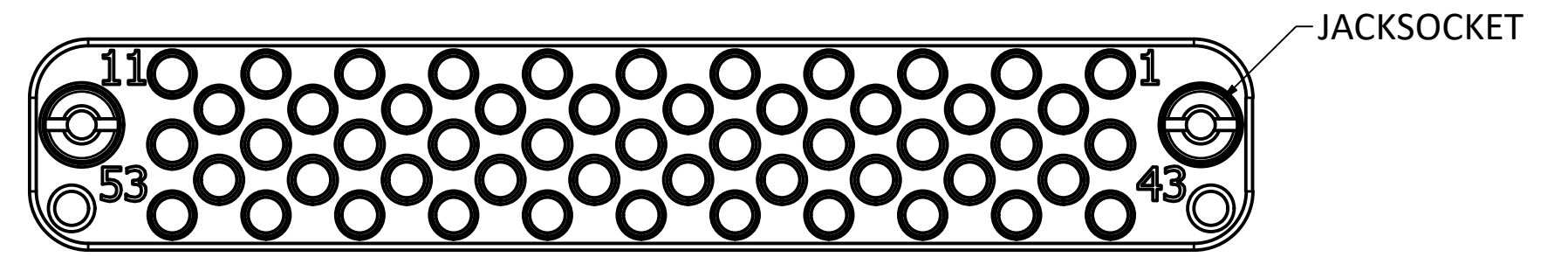
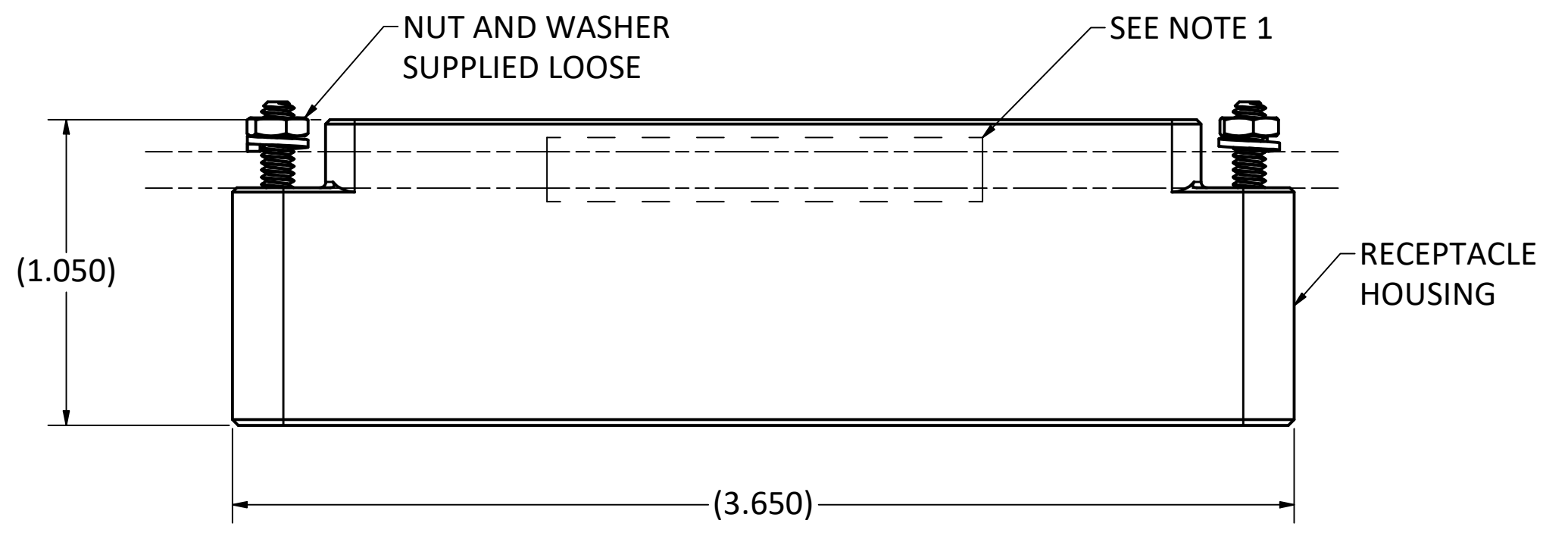

SCALE 1:1

MATERIAL:		<p>WARNING - THIS DOCUMENT CONTAINS TECHNICAL DATA WHOSE EXPORT IS RESTRICTED BY THE ARMS EXPORT CONTROL ACT (TITLE 22, U.S.C., SEC 2751, ET. SEQ.) OR THE EXPORT ADMINISTRATION ACT OF 1979, AS AMENDED, TITLE 50, U.S.C., APP 2401 ET SEQ. VIOLATIONS OF THESE EXPORT LAWS ARE SUBJECT TO SEVERE CRIMINAL PENALTIES. DISSEMINATE IN ACCORDANCE WITH PROVISIONS OF DOD DIRECTIVE 5230.25.</p> <p>This drawing embodies a proprietary design of The Phoenix Company of Chicago, Inc., Naugatuck, CT 06770. All design, manufacturing, reproduction, use, sale, and other rights regarding the same are expressly reserved. The information in this drawing may be covered completely or in part by patents and/or patents pending.</p>		<p>UNLESS OTHERWISE SPECIFIED, PALCO WORKMANSHIP STANDARDS APPLY DIMENSIONS IN INCHES OR [METRIC]</p> <p>DO NOT SCALE PRINTS</p> <p>TOLERANCES ARE: FRACTIONS: ± 1/64 DECIMALS: .XX ± .01 .XXX ± .003 ANGLES: ± 1/2°</p>		<p>The PHOENIX Company of Chicago, Inc.</p> <p>22 GREAT HILL RD., NAUGATUCK, CT 06770 WWW.PHOENIXOFCHICAGO.COM PHONE: (800) 323-9562 FAX:(630) 206-1801</p>		<p>TITLE</p> <p>PX 53-POS PANEL MOUNT RECEPTACLE HOUSING FOR SIZE 16 CONTACTS</p>	
		<p>APPROVALS</p> <p>DRAWN BP 11/15/2024</p> <p>CHECKED AH 2/21/2025</p> <p>QA</p> <p>MFG</p> <p>ENGINEER SJG 2/21/2025</p> <p>APPROVED AH 2/21/2025</p>		<p>DATE</p>		<p>SIZE C FSCM 58167 DWG NO PX16FRDX0XA0000 REV A PLATING OPT.</p>		<p>SCALE 2 : 1 F.S.R. # SHEET 1 OF 1</p>	