

**RECOMMENDED PANEL MOUNTING CUT OUT (MAX. THICKNESS: .125)**

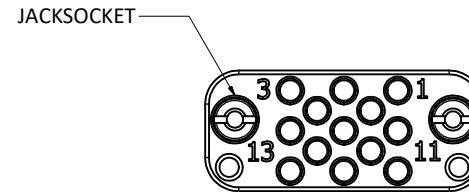

**SPECIFICATIONS:**

1. PART NUMBER: PX16QRDXOXA0000 AND DATE CODE.
2. MATERIALS:
  - a) HOUSING: ACETAL, COLOR: BLACK.
  - b) HOUSING HARDWARE: STAINLESS STEEL.
3. HARDWARE FINISHES: PASSIVATED
4. ELECTRICAL PROPERTIES (APPLIES TO HOUSING ONLY):
  - a) DIELECTRIC STRENGTH: 1,000 VOLTS RMS AT SEA LEVEL; 325 VOLTS RMS AT 70,000 FEET.
  - b) INSULATION RESISTANCE: 1 MEGOHM MINIMUM.
5. ENVIRONMENTAL PROPERTIES:
  - OPERATING TEMPERATURE: -40° F TO +194° F ( -40° C TO +90° C ).

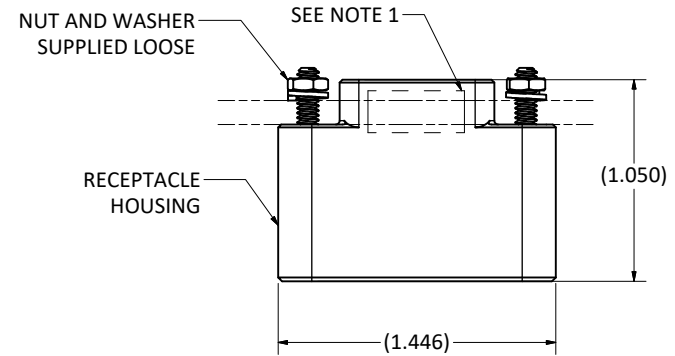
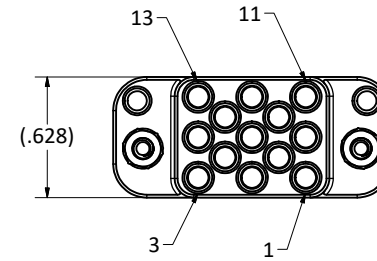
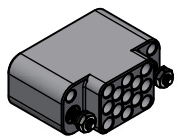

SCALE 1 : 1

MATERIAL:		WARNING - THIS DOCUMENT CONTAINS TECHNICAL DATA WHOSE EXPORT IS RESTRICTED BY THE ARMS EXPORT CONTROL ACT (TITLE 22, U.S.C., SEC 2751, ET. SEQ.) OR THE EXPORT ADMINISTRATION ACT OF 1979, AS AMENDED, TITLE 50, U.S.C., APP 2401 ET SEQ. VIOLATIONS OF THESE EXPORT LAWS ARE SUBJECT TO SEVERE CRIMINAL PENALTIES. DISSEMINATE IN ACCORDANCE WITH PROVISIONS OF DOD DIRECTIVE 5230.25.  This drawing embodies a proprietary design of The Phoenix Company of Chicago, Inc., Naugatuck, CT 06770. All design, manufacturing, reproduction, use, sale, and other rights regarding the same are expressly reserved. The information in this drawing may be covered completely or in part by patents and/or patents pending.		<b>The PHOENIX Company of Chicago, Inc.</b> 22 GREAT HILL RD., NAUGATUCK, CT 06770 WWW.PHOENIXOFCHICAGO.COM PHONE: (800) 323-9562 FAX:(630) 206-1801															
		UNLESS OTHERWISE SPECIFIED, PALCO WORKMANSHIP STANDARDS APPLY DIMENSIONS IN INCHES OR [METRIC] DO NOT SCALE PRINTS TOLERANCES ARE: FRACTIONS: ± 1/64 DECIMALS: .XX ± .01 .XXX ± .003 ANGLES: ± 1/2°		<table border="1"> <thead> <tr> <th>APPROVALS</th> <th>DATE</th> </tr> </thead> <tbody> <tr> <td>DRAWN BP</td> <td>12/3/2024</td> </tr> <tr> <td>CHECKED AH</td> <td>2/7/2025</td> </tr> <tr> <td>QA</td> <td></td> </tr> <tr> <td>MFG</td> <td></td> </tr> <tr> <td>ENGINEER BP</td> <td>2/7/2025</td> </tr> <tr> <td>APPROVED DW</td> <td>3/5/2025</td> </tr> </tbody> </table>		APPROVALS	DATE	DRAWN BP	12/3/2024	CHECKED AH	2/7/2025	QA		MFG		ENGINEER BP	2/7/2025	APPROVED DW	3/5/2025
APPROVALS	DATE																		
DRAWN BP	12/3/2024																		
CHECKED AH	2/7/2025																		
QA																			
MFG																			
ENGINEER BP	2/7/2025																		
APPROVED DW	3/5/2025																		
		<table border="1"> <tr> <td colspan="2">TITLE</td> <td>SIZE</td> <td>FSCM</td> <td>DWG NO</td> <td>REV</td> <td>PLATING OPT.</td> </tr> <tr> <td colspan="2">PX 13-POS PANEL MOUNT RECEPTACLE HOUSING FOR SIZE 16 CONTACTS</td> <td>C</td> <td>58167</td> <td>PX16QRDXOXA0000</td> <td>A</td> <td></td> </tr> </table>		TITLE		SIZE	FSCM	DWG NO	REV	PLATING OPT.	PX 13-POS PANEL MOUNT RECEPTACLE HOUSING FOR SIZE 16 CONTACTS		C	58167	PX16QRDXOXA0000	A			
TITLE		SIZE	FSCM	DWG NO	REV	PLATING OPT.													
PX 13-POS PANEL MOUNT RECEPTACLE HOUSING FOR SIZE 16 CONTACTS		C	58167	PX16QRDXOXA0000	A														
<table border="1"> <thead> <tr> <th>REV</th> <th>DESCRIPTION</th> <th>DATE</th> <th>APPROVAL</th> </tr> </thead> <tbody> <tr> <td>A</td> <td>RELEASED PER ECH 14994</td> <td>3/5/2025</td> <td>DW</td> </tr> </tbody> </table>		REV	DESCRIPTION	DATE	APPROVAL	A	RELEASED PER ECH 14994	3/5/2025	DW	<table border="1"> <tr> <td>SCALE</td> <td>2 : 1</td> <td>F.S.R. #</td> <td>SHEET 1 OF 1</td> </tr> </table>		SCALE	2 : 1	F.S.R. #	SHEET 1 OF 1				
REV	DESCRIPTION	DATE	APPROVAL																
A	RELEASED PER ECH 14994	3/5/2025	DW																
SCALE	2 : 1	F.S.R. #	SHEET 1 OF 1																