

4

3

2

1

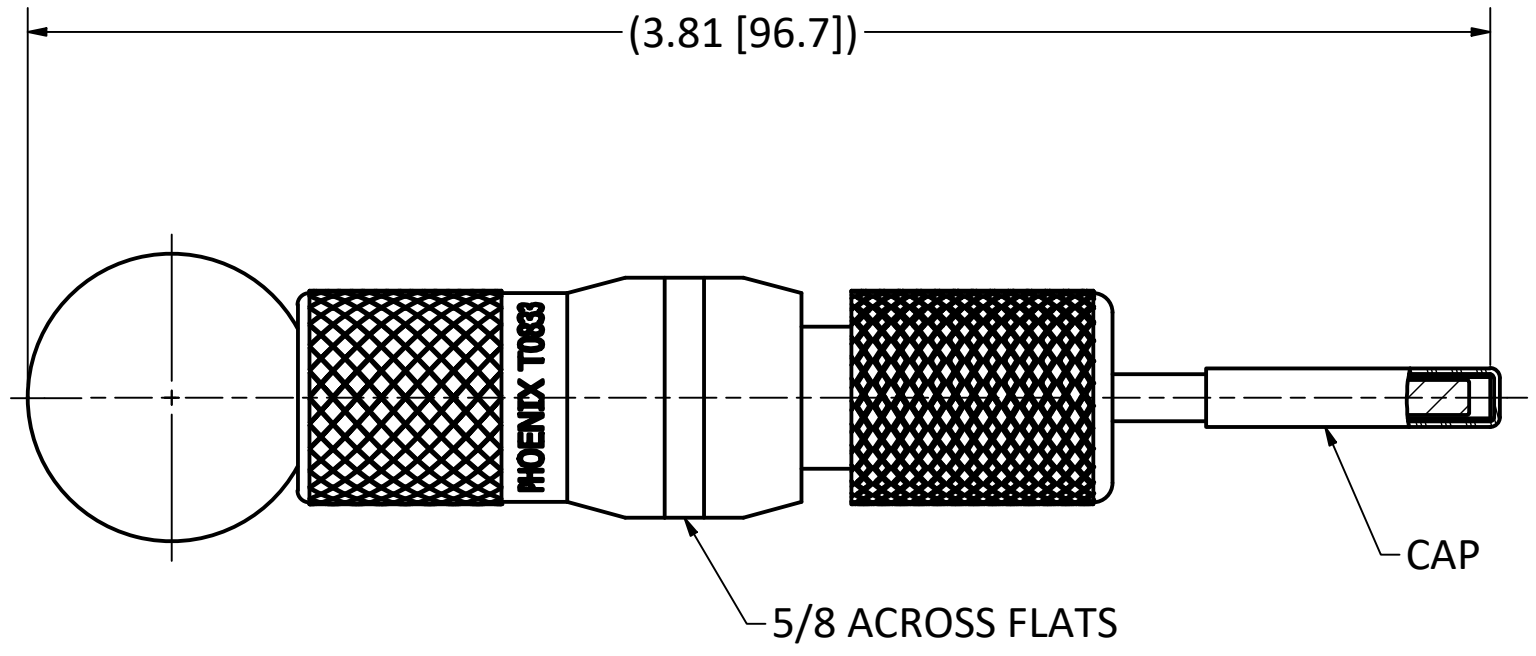

NOTES:

- EXTRACTION INSTRUCTIONS FOR SIZE 16 CONTACTS FROM PX OR PRX HOUSING:
1. INSERT TUBE SIDE OF TOOL INTO MATING SIDE OF HOUSING UNTIL IT STOPS.
 2. PRESS BALL END TO REMOVE CONTACT.

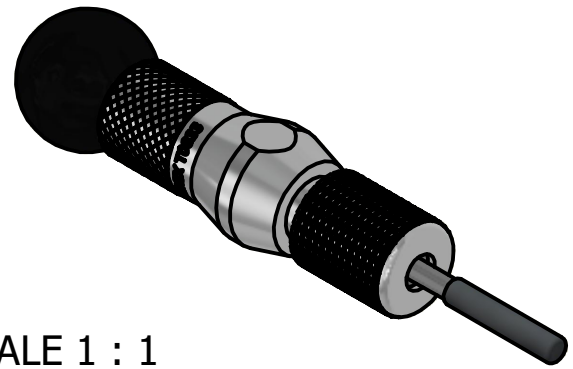

SCALE 1 : 1

<table border="1"> <tr><td>D</td><td>PER ECN 14464</td><td>2/7/2025</td><td>DW</td></tr> <tr><td>C</td><td>PER ECN 14324</td><td>12/6/2024</td><td>DW</td></tr> <tr><td>B</td><td>ECN 12191</td><td>7/28/15</td><td>RMB</td></tr> <tr><td>A</td><td>REL ECN 11580</td><td>2/11/13</td><td>JEM</td></tr> <tr><td>REV.</td><td>DESCRIPTION</td><td>DATE</td><td>BY</td></tr> </table>				D	PER ECN 14464	2/7/2025	DW	C	PER ECN 14324	12/6/2024	DW	B	ECN 12191	7/28/15	RMB	A	REL ECN 11580	2/11/13	JEM	REV.	DESCRIPTION	DATE	BY	<p>THE INFORMATION AND DESIGNS DISCLOSED IN THIS DOCUMENT ARE CONFIDENTIAL AND/OR PROPRIETARY TO THE PHOENIX COMPANY OF CHICAGO INC. AND MAY NOT BE USED FOR MANUFACTURING, REPRODUCED, DISCLOSED TO OTHERS OR FOR ANY OTHER PURPOSE WITHOUT THE EXPRESS WRITTEN CONSENT OF THE PHOENIX COMPANY OF CHICAGO INC.</p>		<p>WARNING - THIS DOCUMENT CONTAINS TECHNICAL DATA WHOSE EXPORT IS RESTRICTED BY THE ARMS EXPORT CONTROL ACT (TITLE 22, U.S.C., SEC 2751, ET. SEQ.) OR THE EXPORT ADMINISTRATION ACT OF 1979, AS AMENDED, TITLE 50, U.S.C., APP 2401 ET SEQ. VIOLATIONS OF THESE EXPORT LAWS ARE SUBJECT TO SEVERE CRIMINAL PENALTIES. DISSEMINATE IN ACCORDANCE WITH PROVISIONS OF DOD DIRECTIVE 5230.25.</p>		<p>UNLESS OTHERWISE SPECIFIED, PHOENIX WORKMANSHIP STANDARDS APPLY DIMENSIONS IN INCHES OR [METRIC]</p> <p>DO NOT SCALE PRINTS</p> <p>TOLERANCES ARE: FRACTIONS: ± 1/64 DECIMALS: .XX ± .01 .XXX ± .003 ANGLES: ± 1/2°</p>		<table border="1"> <tr><th colspan="2">APPROVALS</th><th>DATE</th></tr> <tr><td>DRAWN</td><td>JEM</td><td>2/11/13</td></tr> <tr><td>CHECKED</td><td>RMB</td><td>7/28/15</td></tr> <tr><td>QA</td><td></td><td></td></tr> <tr><td>MFG</td><td></td><td></td></tr> <tr><td>ENGINEER</td><td>JEM</td><td>2/11/13</td></tr> <tr><td>APPROVED</td><td>RMB</td><td>7/28/15</td></tr> </table>		APPROVALS		DATE	DRAWN	JEM	2/11/13	CHECKED	RMB	7/28/15	QA			MFG			ENGINEER	JEM	2/11/13	APPROVED	RMB	7/28/15	<p>The PHOENIX Company of Chicago, Inc.</p> <p>22 GREAT HILL RD., NAUGATUCK, CT 06770 WWW.PHOENIXOFCHICAGO.COM PHONE: (800) 323-9562 FAX:(630) 206-1801</p>			
D	PER ECN 14464	2/7/2025	DW																																																					
C	PER ECN 14324	12/6/2024	DW																																																					
B	ECN 12191	7/28/15	RMB																																																					
A	REL ECN 11580	2/11/13	JEM																																																					
REV.	DESCRIPTION	DATE	BY																																																					
APPROVALS		DATE																																																						
DRAWN	JEM	2/11/13																																																						
CHECKED	RMB	7/28/15																																																						
QA																																																								
MFG																																																								
ENGINEER	JEM	2/11/13																																																						
APPROVED	RMB	7/28/15																																																						
						<p>TITLE</p> <p>EXTRACTION TOOL FOR SIZE 16 PkZ® CONTACTS</p>																																																		
		SIZE	FSCM	DWG NO	REV	PLATING OPT.																																																		
		B	58167	T0833	D																																																			
				SCALE	F.S.R. #	SHEET 1 OF 1																																																		

4

3

2

1